

CATALOG

HYDRAULIC BEAD BREAKERS



**100% MADE IN ITALY
SINCE 1980**



New location





DI MONTRESOR GIANFRANCO®

CHI SIAMO

PMM Montresor progetta e produce stallonatori idraulici portatili, per lo smontaggio di pneumatici di piccole e grande dimensioni, fin dal 1980.

L'azienda è costantemente impegnata nello sviluppo di nuove idee, nuove tecnologie e nella ricerca di nuovi materiali per offrire al cliente dei prodotti sempre più di alta qualità, innovativi, affidabili e sempre più performanti.

ABOUT US

PMM Montresor designs and manufactures portable hydraulic bead breakers for dismounting small and big tires, since 1980. The company is constantly engaged in developing new ideas, new technologies, researching new materials just to offer to the client high quality products, innovative, affordable and more performing.

QUI SOMMES-NOUS

PMM Montresor conçoit et produit des détalonneurs hydrauliques portables, pour le démontage des pneus aux dimensions soit petites que grandes depuis le 1980.

L'entreprise est toujours engagée à développer des nouvelles idées et technologies dans la recherche des matières nouvelles pour offrir au client des produits de plus en plus de haute qualité, innovantes et fiables et toujours plus performants.



www.pmm-montresor.com



info@pmm-montresor.com



[pmm di montresor gianfranco](https://www.youtube.com/pmm-di-montresor-gianfranco)

LA DITTA SI RISERVA IL DIRITTO DI APPORTARE MODIFICHE AL PRODOTTO SENZA PREAVVISO
THE COMPANY RESERVES THE RIGHT TO MAKE CHANGES TO THE PRODUCT WITHOUT NOTICE
LA SOCIÉTÉ SE RÉSERVE LE DROIT D'APPORTER DES MODIFICATIONS AUX PRODUITS SANS PRÉAVIS



Via del Commercio 15 -37066-Sommacampagna-Verona-ITALY
 TEL: +39 045 8960428 FAX: +39 045 8978641
 E-MAIL: info@pmm-montresor.com
 WEB SITE: www.pmm-montresor.com

MANUFACTURER SINCE 1980

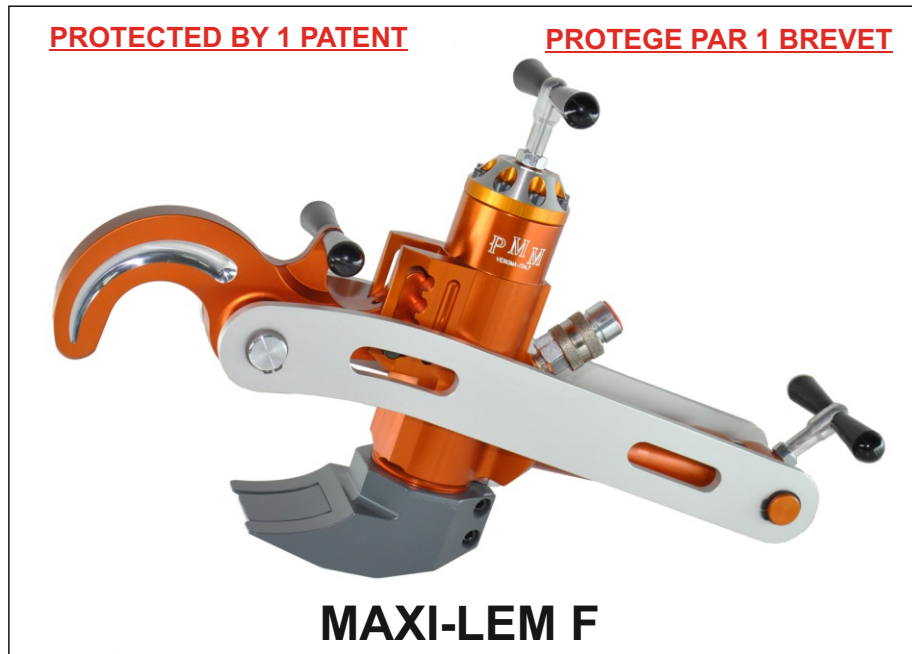

PROTECTED BY 1 PATENT

PROTEGE PAR 1 BREVET

MAXI-LEM F

The MAXI-LEM F can be used to detach the bead of the tyre on both sides of the rim for earth-moving machines which are equipped with pieces rims in three pieces up to 29".

MAXI-LEM F est utilisé pour décoller le talon du pneu des deux côtés de la jante des engins de terrassement avec les jantes à 3 pièces jusqu'à 29".

Il MAXI-LEM F è adatto per stallonare il tallone del pneumatico da ambo i lati del cerchione di macchine per movimento terra che utilizzano cerchioni a 3 pezzi, fino a 29".

Characteristics

Adjustable claw
 Weight: 13,2 kg
 Dimensions: 57x11x35 cm
 Stem stroke: **11,5 cm**
 Bead breaking power: 4536 kg
 Clamping power: from 3400kg to 7930kg
 Foot mechanical: 7,5 cm
 Max. dimensions of tyres: 29"
 Max. operating pressure: 700 bar

Caractéristiques

Griffe réglable
 Poids: 13,2 kg
 Dimensions: 57x11x35 cm
 Course de détalonnage: **11,5 cm**
 Puissance détalonnage: 4536 kg
 Puissance blocage: de 3400 kg à 7930 kg
 Pied mécaniques: 7,5 cm
 Dimensions pneus max: 29"
 Pression de fonct. max: 700 bar

Caratteristiche

Becco regolabile
 Peso attrezzo: 13,2 kg
 Dimensioni attrezzo: 57x11x35 cm
 Corsa stelo stallonatore: **11,5 cm**
 Potenza stallonatura: 4536 kg
 Potenza bloccaggio: da 3400kg a 7930kg
 Lunghezza piedini: 7,5 cm
 Dimensioni pneumatici max: 29"
 Pressione di esercizio max: 700 bar



MADE IN ITALY





Via del Commercio 15 -37066-Sommacampagna-Verona-ITALY
 TEL: +39 045 8960428 FAX: +39 045 8978641
 E-MAIL: info@pmm-montresor.com
 WEB SITE: www.pmm-montresor.com

MANUFACTURER SINCE 1980

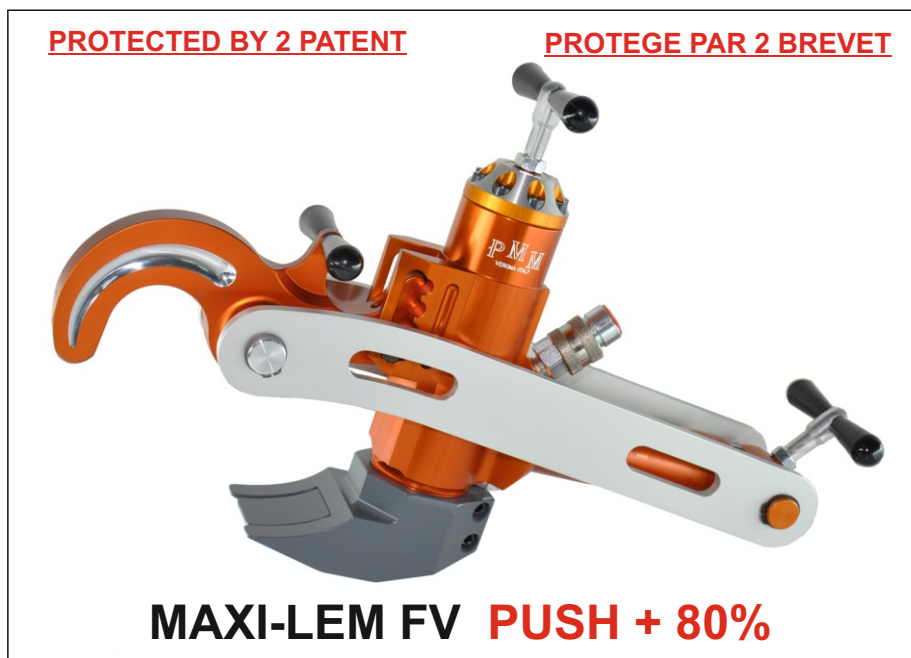

PROTECTED BY 2 PATENT

PROTEGE PAR 2 BREVET

MAXI-LEM FV PUSH + 80%

The MAXI-LEM **FV** can be used to detach the bead of the tyre on both sides of the rim for earth-moving machines which are equipped with pieces rims in three pieces up to 29".

MAXI-LEM **FV** est utilisé pour décoller le talon du pneu des deux côtés de la jante des engins de terrassement avec les jantes à 3 pièces jusqu'à 29".

Il MAXI-LEM **FV** è adatto per stallonare il tallone del pneumatico da ambo i lati del cerchione di macchine per movimento terra che utilizzano cerchioni a 3 pezzi, fino a 29".

Characteristics

Adjustable claw
 Weight: 13,2 kg
 Dimensions: 57x11x35 cm
 Stem stroke: **11,5 cm**
 Bead breaking power: **8000 kg**
 Clamping power: from 5500kg to 7930kg
 Foot mechanical: 7,5 cm
 Max. dimensions of tyres: 29"
 Max. operating pressure: 700 bar

Caractéristiques

Griffe réglable
 Poids: 13,2 kg
 Dimensions: 57x11x35 cm
 Course de détalonnage: **11,5 cm**
 Puissance détalonnage: **8000 kg**
 Puissance blocage: de 5500kg à 7930 kg
 Pied mécaniques: 7,5 cm
 Dimensions pneus max: 29"
 Pression de fonct. max: 700 bar

Caratteristiche

Becco regolabile
 Peso attrezzo: 13,2 kg
 Dimensioni attrezzo: 57x11x35 cm
 Corsa stelo stallonatore: **11,5 cm**
 Potenza stallonatura: **8000 kg**
 Potenza bloccaggio: da 5500kg a 7930kg
 Lunghezza piedini: 7,5 cm
 Dimensioni pneumatici max: 29"
 Pressione di esercizio max: 700 bar



MADE IN ITALY





Via del Commercio 15 -37066-Sommacampagna-Verona-ITALY
 TEL: +39 045 8960428 FAX: +39 045 8978641
 E-MAIL: info@pmm-montresor.com
 WEB SITE: www.pmm-montresor.com

MANUFACTURER SINCE 1980

PROTECTED BY 2 PATENT

PROTEGE PAR 2 BREVET



MAXI-LEM SPECIAL F

The MAXI-LEM SPECIAL F can be used to detach the bead of the tyre on both sides of the rim for earth-moving machines which are equipped with pieces rims in 3-5 pieces up to 35".

MAXI-LEM SPECIAL F est utilisé pour décoller le talon du pneu des deux côtés de la jante des engins de terrassement avec les jantes de 3 à 5 pièces jusqu'à 35".

Il MAXI-LEM SPECIAL F è adatto a stallonare il tallone del pneumatico da entrambi i lati del cerchione di veicoli movimento terra che utilizzano cerchioni da 3-5 pezzi fino a 35".

Characteristics

Adjustable claw

Weight: 14 kg
 Dimensions: 57x11x36 cm
 Stem stroke: **11,4 cm**
 Bead breaking power: 4536 kg
 Clamping power: from 3400kg to 7930kg
 Foot mechanical: **10 cm**
 Max. dimensions of tyres: **35"**
 Max. operating pressure: 700 bar

Caractéristiques

Griffe réglable
 Poids: 14 kg
 Dimensions: 57x11x36 cm
 Course de détalonnage: **11,4 cm**
 Puissance détalonnage: 4536 kg
 Puissance blocage: de 3400kg à 7930kg
 Pied mécaniques: **10 cm**
 Dimensions pneus max: **35"**
 Pression de fonct. max: 700 bar

Caratteristiche

Becco regolabile
 Peso attrezzo: 14 kg
 Dimensioni attrezzo: 57x11x35 cm
 Corsa stelo stallonatore: **11,4 cm**
 Potenza stallonatura: 4536 kg
 Potenza bloccaggio: da 3400kg a 7930kg
 Lunghezza piedini: **10 cm**
 Dimensioni pneumatici max: **35"**
 Pressione di esercizio max: 700 bar



MADE IN ITALY





Via del Commercio 15 -37066-Sommacampagna-Verona-ITALY
 TEL: +39 045 8960428 FAX: +39 045 8978641
 E-MAIL: info@pmm-montresor.com
 WEB SITE: www.pmm-montresor.com

MANUFACTURER SINCE 1980

PROTECTED BY 3 PATENT

PROTEGE PAR 3 BREVET



MAXI-LEM SPECIAL FV PUSH + 80%

The MAXI-LEM SPECIAL **FV** can be used to detach the bead of the tyre on both sides of the rim for earth-moving machines which are equipped with pieces rims in 3-5 pieces up to 35".

MAXI-LEM SPECIAL **FV** est utilisé pour décoller le talon du pneu des deux côtés de la jante des engins de terrassement avec les jantes de 3 à 5 pièces jusqu'à 35".

Il MAXI-LEM SPECIAL **FV** è adatto a stallonare il tallone del pneumatico da entrambi i lati del cerchione di veicoli movimento terra che utilizzano cerchioni da 3-5 pezzi fino a 35".

Characteristics

Adjustable claw

Weight: 14 kg
 Dimensions: 57x11x36 cm
 Stem stroke: **11,4 cm**
 Bead breaking power: **8000 kg**
 Clamping power: **from 5500kg** to 7930kg
 Foot mechanical: **10 cm**
 Max. dimensions of tyres: **35"**
 Max. operating pressure: 700 bar

Caractéristiques

Griffe réglable

Poids: 14 kg
 Dimensions: 57x11x36 cm
 Course de détalonnage: **11,4 cm**
 Puissance détalonnage: **8000 kg**
 Puissance blocage: **de 5500kg** à 7930kg
 Pied mécaniques: **10 cm**
 Dimensions pneus max: **35"**
 Pression de fonct. max: 700 bar

Caratteristiche

Becco regolabile

Peso attrezzo: 14 kg
 Dimensioni attrezzo: 57x11x35 cm
 Corsa stelo stallonatore: **11,4 cm**
 Potenza stallonatura: **8000 kg**
 Potenza bloccaggio: **da 5500kg** a 7930kg
 Lunghezza piedini: **10 cm**
 Dimensioni pneumatici max: **35"**
 Pressione di esercizio max: 700 bar



MADE IN ITALY





Via del Commercio 15 -37066-Sommacampagna-Verona-ITALY
 TEL: +39 045 8960428 FAX: +39 045 8978641
 E-MAIL: info@pmm-montresor.com
 WEB SITE: www.pmm-montresor.com

MANUFACTURER SINCE 1980

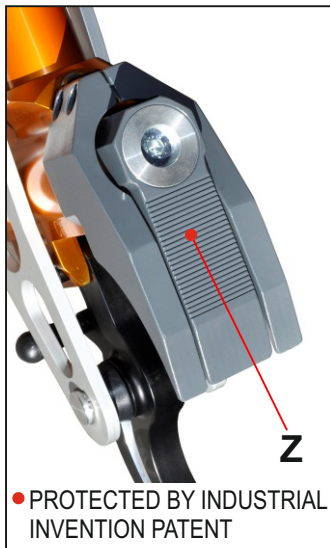

● PROTECTED BY INDUSTRIAL INVENTION PATENT

PROTECTED BY 3 PATENT

PROTEGE PAR 3 BREVET



PUSH + 80%

MAXI-LEM SPECIAL FV BS/80 DCZ

The MAXI-LEM SPECIAL FV BS/80 DCZ can be used to detach the bead of the tyre on both sides of the rim for earth-moving machines which are equipped with pieces rims in 3-5 pieces up to 35".

MAXI-LEM SPECIAL FV BS/80 DCZ est utilisé pour décoller le talon du pneu des deux côtés de la jante des engins de terrassement avec les jantes de 3 à 5 pièces jusqu'à 35".

Il MAXI-LEM SPECIAL FV BS/80 DCZ è adatto a stallonare il tallone del pneumatico da entrambi i lati del cerchione di veicoli movimento terra che utilizzano cerchioni da 3-5 pezzi fino a 35".

Characteristics

Adjustable claw

Weight: 14,2 kg
 Dimensions: 59x11x36 cm
 Stem stroke: 7 cm
 Bead breaking power: **8000 kg**
 Clamping power: **from 5500kg** to 7930kg
 Foot mechanical: **10 cm**
 Max. dimensions of tyres: **35"**
 Max. operating pressure: 700 bar

Caractéristiques

Griffe réglable

Poids: 14,2 kg
 Dimensions: 59x11x36 cm
 Course de détalonnage: 7 cm
 Puissance détalonnage: **8000 kg**
 Puissance blocage: **de 5500kg** à 7930kg
 Pied mécaniques: **10 cm**
 Dimensions pneus max: **35"**
 Pression de fonct. max: 700 bar

Caratteristiche

Becco regolabile

Peso attrezzo: 14,2 kg
 Dimensioni attrezzo: 59x11x35 cm
 Corsa stelo stallonatore: 7 cm
 Potenza stallonatura: **8000 kg**
 Potenza bloccaggio: **da 5500kg** a 7930kg
 Lunghezza piedini: **10 cm**
 Dimensioni pneumatici max: **35"**
 Pressione di esercizio max: 700 bar



MADE IN ITALY





Via del Commercio 15 -37066-Sommacampagna-Verona-ITALY
 TEL: +39 045 8960428 FAX: +39 045 8978641
 E-MAIL: info@pmm-montresor.com
 WEB SITE: www.pmm-montresor.com

MANUFACTURER SINCE 1980

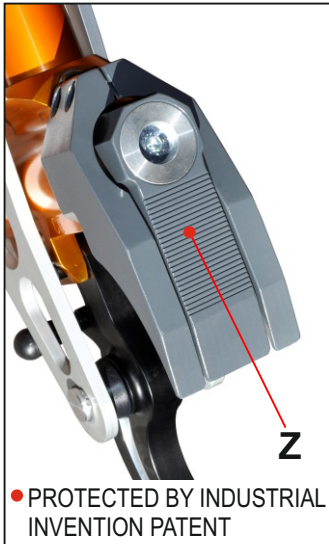

• PROTECTED BY INDUSTRIAL INVENTION PATENT

PROTECTED BY 2 PATENT

PROTEGE PAR 2 BREVET



PUSH + 80%
MAXI-LEM SPECIAL FV 42 BS/80 DCZ

The hydraulic bead breaker **MAXI-LEM SPECIAL FV 42 BS/80 DCZ** can be used to detach the bead of the tyre on both sides of the rim for earth-moving machines which are equipped with pieces rims in 3-5 pieces up to 35".

Le détalonneur hydraulique **MAXI-LEM SPECIAL FV 42 BS/80 DCZ** est utilisé pour décoller le talon du pneu des deux côtés de la jante des engins de terrassement avec les jantes de 3 à 5 pièces jusqu'à 35".

Lo stallonatore idraulico **MAXI-LEM SPECIAL FV 42 BS/80 DCZ** è adatto a stallonare il tallone del pneumatico da entrambi i lati del cerchione di veicoli movimento terra che utilizzano cerchioni da 3-5 pezzi fino a 35".

Characteristics

Adjustable claw
 Weight: 14,5 kg
 Dimensions: 59x11x36 cm
 Stem stroke: 7 cm
 Bead breaking power: **8000 kg**
 Clamping power: **from 6200kg to 9700kg**
 Foot mechanical: **10 cm**
 Max. dimensions of tyres: **35"**
 Max. operating pressure: 700 bar

Caractéristiques

Griffe réglable
 Poids: 14,5 kg
 Dimensions: 59x11x36 cm
 Course de détalonnage: 7 cm
 Puissance détalonnage: **8000 kg**
 Puissance blocage: **de 6200kg à 9700kg**
 Pied mécaniques: **10 cm**
 Dimensions pneus max: **35"**
 Pression de fonct. max: 700 bar

Caratteristiche

Becco regolabile
 Peso attrezzo: 14,5 kg
 Dimensioni attrezzo: 59x11x36 cm
 Corsa stelo stallonatore: 7 cm
 Potenza stallonatura: **8000 kg**
 Potenza bloccaggio: **da 6200kg a 9700kg**
 Lunghezza piedini: **10 cm**
 Dimensioni pneumatici max: **35"**
 Pressione di esercizio max: 700 bar



MADE IN ITALY





Via del Commercio 15 -37066-Sommacampagna-Verona-ITALY
 TEL: +39 045 8960428 FAX: +39 045 8978641
 E-MAIL: info@pmm-montresor.com
 WEB SITE: www.pmm-montresor.com

MANUFACTURER SINCE 1980

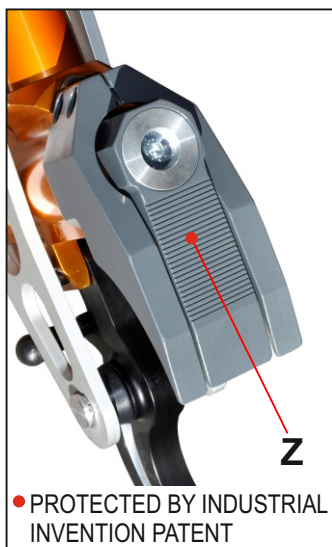

• PROTECTED BY INDUSTRIAL INVENTION PATENT

PROTECTED BY 4 PATENTS

PROTEGES PAR 4 BREVETS

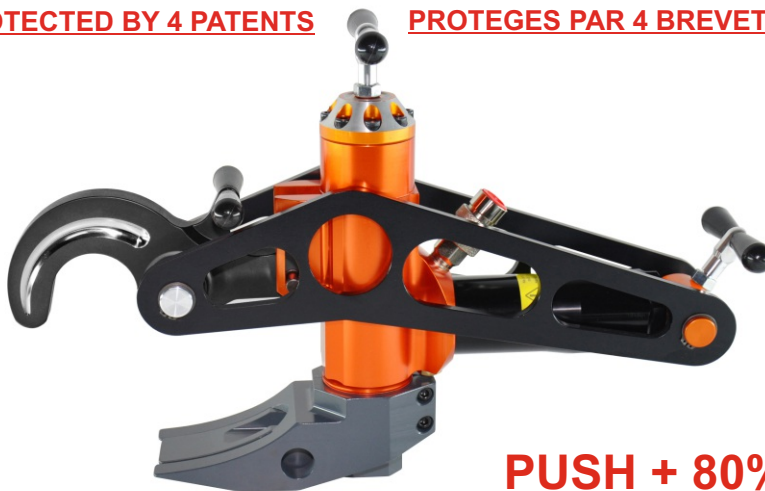

PUSH + 80%

MAXI-LEM SPECIAL FV 13/42 BS/80 DCZ

The hydraulic bead breaker **MAXI-LEM SPECIAL FV 13/42 BS/80 DCZ** can be used to detach the bead of the tyre on both sides of the rim for earth-moving machines which are equipped with pieces rims in 3-5 pieces up to 49" with shoulder of the rim 12 cm high.

Le détalonneur hydraulique **MAXI-LEM SPECIAL FV 13/42 BS/80 DCZ** est utilisé pour décoller le talon du pneu sur les deux côtés de la jante des engins de terrassement de 3 à 5 pièces jusqu'à 49" avec une jante épaule 12 cm haut

Lo stallonatore idraulico **MAXI-LEM SPECIAL FV 13/42 BS/80 DCZ** è adatto a stallonare il tallone del pneumatico da ambo i lati del cerchione di macchine movimento terra attrezzate con cerchioni da 3 e 5 pezzi fino a 49" con spalla del cerchione alta 12 cm.

Characteristics

Adjustable claw
 Weight: 15,5kg
 Dimensions: 59x11x36 cm
 Stem stroke: 7 cm
 Bead breaking power: **8000 kg**
 Clamping power: **from 6200kg to 9700kg**
 Foot mechanical: **13 cm**
 Max. dimensions of tyres: **49"**
 Max. operating pressure: 700 bar

Caractéristiques

Griffe réglable
 Poids: 15,5 kg
 Dimensions: 59x11x36 cm
 Course de détalonnage: 7 cm
 Puissance détalonnage: **8000 kg**
 Puissance blocage: **de 6200kg à 9700kg**
 Pied mécaniques: **13 cm**
 Dimensions pneus max: **49"**
 Pression de fonct. max: 700 bar

Caratteristiche

Becco regolabile
 Peso attrezzo: 15,5 kg
 Dimensioni attrezzo: 59x11x36 cm
 Corsa stelo stallonatore: 7 cm
 Potenza stallonatura: **8000 kg**
 Potenza bloccaggio: **da 6200kg a 9700kg**
 Lunghezza piedini: **13 cm**
 Dimensioni pneumatici max: **49"**
 Pressione di esercizio max: 700 bar



MADE IN ITALY





Via del Commercio 15 -37066-Sommacampagna-Verona-ITALY
 TEL: +39 045 8960428 FAX: +39 045 8978641
 E-MAIL: info@pmm-montresor.com
 WEB SITE: www.pmm-montresor.com

MANUFACTURER SINCE 1980



MAXI-LEM 40T is purposely designed for breaking Mod.18-0033 40" crossply tires mounted on cranes and container handling (such as Bellotti, C.V.S., Ferrari, Kalmar, Terex), from both sides of the rim.

MAXI-LEM 40T est spécialement conçu pour décoller les pneus Mod. 18-0033 à 40 crossply (pneus à carcasse diagonale) montés sur les grues en général et surtout sur les grues portuaires (voir Bellotti, C.V.S., Ferrari, Kalmar, Terex) sur les deux côtés de la jante.

MAXI-LEM 40T è studiato appositamente per stallonare il tallone dei pneumatici Mod. 18-0033 da 40 tele montati su gru e porta container (tipo Bellotti, C.V.S., Ferrari, Kalmar, Terex) da ambo i lati del cerchione.

Characteristics

Adjustable claw
 Weight: 14,2 kg
 Dimensions: 59x11x36 cm
 Stem stroke: 7 cm
 Bead breaking power: **12600 kg**
 Clamping power: **from 5500kg** to 7930 kg
 Foot mechanical: **10 cm**
 Max. operating pressure: 700 bar

Caratteristiche

Becco regolabile
 Peso attrezzo: 14,2 kg
 Dimensioni attrezzo: 59x11x36 cm
 Corsa stelo stallonatore: 7 cm
 Potenza stallonatura: **12600 kg**
 Potenza bloccaggio: **da 5500kg** a 7930kg
 Lunghezza piedini: **10 cm**
 Pressione di esercizio max: 700 bar

Caractéristiques

Griffe réglable
 Poids: 14,2 kg
 Dimensions: 59x11x36 cm
 Course de détalonnage: 7 cm
 Puissance détalonnage: **12600 kg**
 Puissance blocage: **de 5500kg** à 7930kg
 Pied mécaniques: **10 cm**
 Pression de fonct. max: 700 bar

 MADE IN ITALY



La gamma Super monta lo stelo DC





Via del Commercio 15 -37066-Sommacampagna-Verona-ITALY
 TEL: +39 045 8960428 FAX: +39 045 8978641
 E-MAIL: info@pmm-montresor.com
 WEB SITE: www.pmm-montresor.com

MANUFACTURER SINCE 1980

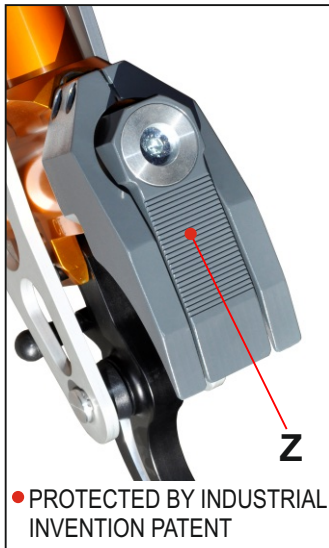

● PROTECTED BY INDUSTRIAL INVENTION PATENT

PROTECTED BY 2 PATENT

PROTEGE PAR 2 BREVET



PUSH + 180%

MAXI-LEM SUPER FV 42 BS/80 Z

The MAXI-LEM SUPER FV 42 BS/80 Z can be used to detach the bead of the tyre on both sides of the rim for earth-moving machines which are equipped with pieces rims in 3-5 pieces up to 35".

MAXI-LEM SUPER FV 42 BS/80 Z est utilisé pour décoller le talon du pneu des deux côtés de la jante des engins de terrassement avec les jantes de 3 à 5 pièces jusqu'à 35".

Il MAXI-LEM SUPER FV 42 BS/80 Z è adatto a stallonare il tallone del pneumatico da entrambi i lati del cerchione di veicoli movimento terra che utilizzano cerchioni da 3-5 pezzi fino a 35".

Characteristics

Adjustable claw
 Weight: 14,5 kg
 Dimensions: 59x11x36 cm
 Stem stroke: 7 cm
 Bead breaking power: **12600 kg**
 Clamping power: **from 6200kg to 9700kg**
 Foot mechanical: **10 cm**
 Max. dimensions of tyres: **35"**
 Max. operating pressure: 700 bar

Caractéristiques

Griffe réglable
 Poids: 14.5 kg
 Dimensions: 59x11x36 cm
 Course de détalonnage: 7 cm
 Puissance détalonnage: **12600 kg**
 Puissance blocage: **de 6200kg à 9700kg**
 Pied mécaniques: **10 cm**
 Dimensions pneus max: **35"**
 Pression de fonct. max: 700 bar

Caratteristiche

Becco regolabile
 Peso attrezzo: 14,5 kg
 Dimensioni attrezzo: 59x11x36 cm
 Corsa stelo stallonatore: 7 cm
 Potenza stallonatura: **12600 kg**
 Potenza bloccaggio: **da 6200kg a 9700kg**
 Lunghezza piedini: **10 cm**
 Dimensioni pneumatici max: **35"**
 Pressione di esercizio max: 700 bar



MADE IN ITALY



La gamma Super monta lo stelo DC



Via del Commercio 15 -37066-Sommacampagna-Verona-ITALY
 TEL: +39 045 8960428 FAX: +39 045 8978641
 E-MAIL: info@pmm-montresor.com
 WEB SITE: www.pmm-montresor.com

MANUFACTURER SINCE 1980

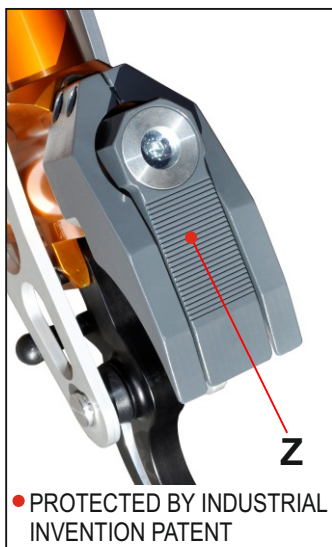

PROTECTED BY 4 PATENTS

PROTEGES PAR 4 BREVETS



PUSH + 180%

MAXI-LEM SUPER FV 13/42 BS/80 DCZ

The MAXI-LEM SUPER FV 13/42 BS/80 DCZ can be used to detach the bead of the tyre on both sides of the rim for earth-moving machines which are equipped with pieces rims in 3-5 pieces up to 49" with shoulder of the rim 12 cm high.

MAXI-LEM SUPER FV 13/42 BS/80 DCZ est utilisé pour décoller le talon du pneu sur les deux côtés de la jante des engins de terrassement de 3 à 5 pièces jusqu'à 49" avec une jante épaulement 12 cm haut

Il MAXI-LEM SUPER FV 13/42 BS/80 DCZ è adatto a stallonare il tallone del pneumatico da ambo i lati del cerchione di macchine movimento terra attrezzate con cerchioni da 3 e 5 pezzi fino a 49" con spalla del cerchione alta 12 cm.

Characteristics

Adjustable claw
 Weight: 15,5 kg
 Dimensions: 59x11x36 cm
 Stem stroke: 7 cm
 Bead breaking power: **12600 kg**
 Clamping power: **from 6200kg to 9700kg**
 Foot mechanical: **13 cm**
 Max. dimensions of tyres: **49"**
 Max. operating pressure: 700 bar

Caractéristiques

Griffe réglable
 Poids: 15,5 kg
 Dimensions: 59x11x36 cm
 Course de détalonnage: 7 cm
 Puissance détalonnage: **12600 kg**
 Puissance blocage: **de 6200kg à 9700kg**
 Pied mécaniques: **13 cm**
 Dimensions pneus max: **49"**
 Pression de fonct. max: 700 bar

Caratteristiche

Becco regolabile
 Peso attrezzo: 15,5 kg
 Dimensioni attrezzo: 59x11x36 cm
 Corsa stelo stallonatore: 7 cm
 Potenza stallonatura: **12600 kg**
 Potenza bloccaggio: **da 6200kg a 9700kg**
 Lunghezza piedini: **13 cm**
 Dimensioni pneumatici max: **49"**
 Pressione di esercizio max: 700 bar



La gamma Super monta lo stelo DC



Via del Commercio 15 -37066-Sommacampagna-Verona-ITALY
TEL: +39 045 8960428 FAX: +39 045 8978641
E-MAIL: info@pmm-montresor.com
WEB SITE: www.pmm-montresor.com

MANUFACTURER SINCE 1980

**PROTECTED BY INDUSTRIAL
INVENTION PATENT**

PROTEGE PAR 1 BREVET



CU3/4

CU1/4

SPESSORI ANTISCIVOLO



Wedges with these different measures have been properly designed with an “antislip” system so that the bead may be moved from the tire during the breaking completely safely.

Ces câles ont plusieurs mesures et ont été conçues avec un système “antidérapant” afin que le talon reste loin du pneu lors du détalonnage en tout sécurité.

Questi spessori di varie misure sono stati studiati appositamente con un sistema “antiscivolo” per tenere spostato il tallone del pneumatico durante la fase di stallonamento in totale sicurezza.





Via del Commercio 15 -37066-Sommacampagna-Verona-ITALY
TEL: +39 045 8960428 FAX: +39 045 8978641
E-MAIL: info@pmm-montresor.com
WEB SITE: www.pmm-montresor.com

MANUFACTURER SINCE 1980

BS/80



BS/70



BS/70 VOLVO



MADE IN ITALY





Via del Commercio 15 -37066-Sommacampagna-Verona-ITALY
 TEL: +39 045 8960428 FAX: +39 045 8978641
 E-MAIL: info@pmm-montresor.com
 WEB SITE: www.pmm-montresor.com

MANUFACTURER SINCE 1980

PROTECTED BY 1 PATENT

PROTEGE PAR 1 BREVET



MINI GROVER



The MINI GROVER is purposely designed to detach the inside bead of tyres, especially the ones of terrain cranes with Megatrak™ suspensions.

Le MINI GROVER est surtout conçu pour décoller l'intérieur du talon des pneus, en particulier ceux des grues tout-terrain aux suspensions Megatrak™.

Il MINI GROVER è adatto per stallonare il tallone interno dei pneumatici, in particolare quelli montati sulle gru tuttoterreno con sospensioni Megatrak™.

Characteristics

Adjustable claw
 Weight: 8,7 kg
 Dimensions: 45x11x32 cm
 Stem stroke: 7 cm
 Bead breaking power: 2830 kg
 Clamping power: from 2120kg to 4950kg
 Foot mechanical: 4,5 cm
 Max. dimensions of tyres:25"
 Max. operating pressure: 700 bar

Caractéristiques

Griffe réglable
 Poids: 8,7 kg
 Dimensions: 45x11x32 cm
 Course de détalannage: 7 cm
 Puissance détalonnage: 2830 kg
 Puissance blocage: de 2120 kg à 4950kg
 Pied mécaniques: 4,5 cm
 Dimensions pneus max: 25"
 Pression de fonct. max: 700 bar

Caratteristiche

Becco regolabile
 Peso attrezzo: 8,7 kg
 Dimensioni attrezzo: 45x11x32 cm
 Corsa stelo stallonatore: 7 cm
 Potenza stallonatura: 2830 kg
 Potenza bloccaggio: da 2120kg a 4950kg
 Lunghezza piedino: 4,5 cm
 Dimensioni pneumatici max: 25"
 Pressione di esercizio max: 700 bar



MADE IN ITALY





Via del Commercio 15 -37066-Sommacampagna-Verona-ITALY
 TEL: +39 045 8960428 FAX: +39 045 8978641
 E-MAIL: info@pmm-montresor.com
 WEB SITE: www.pmm-montresor.com

MANUFACTURER SINCE 1980

PROTECTED BY 1 PATENT

PROTEGE PAR 1 BREVET



MINI-LEM F

The MINI-LEM F can be used to the inside and outside tyre bead of all types of tyres up to 24": trucks, combine-harvesters and tractors up to 150 HP.

MINI-LEM F est utilisé soit à l'intérieur qu'à l'extérieur du talon des pneus de tout genre jusqu'à 24": camions, moissonneuses-batteuses et tracteurs jusqu'à 150 HP.

Il MINI-LEM F è adatto per stallonare il tallone interno ad esempio di tutti i tipi di pneumatici fino a 24": camion, mietitrebbia e trattori fino a 150 HP.

Characteristics

Weight: 8,7 kg
 Dimensions: 50x11x32 cm
 Stem stroke: **10 cm**
 Bead breaking power: 2830 kg
 Clamping power: from 2120kg to 4950kg
 Foot mechanical: 4,3 cm
 Max. dimensions of tyres:24"
 Max. operating pressure: 700 bar

Caratteristiche

Peso attrezzo: 8,7 kg
 Dimensioni attrezzo: 50x11x32 cm
 Corsa stelo stallonatore: **10 cm**
 Potenza stallonatura: 2830 kg
 Potenza bloccaggio: da 2120kg a 4950kg
 Lunghezza piedino: 4,3 cm
 Dimensioni pneumatici max: 24"
 Pressione di esercizio max: 700 bar

Caractéristiques

Poids: 8,7 kg
 Dimensions: 50x11x32 cm
 Course de détalannage: **10 cm**
 Puissance détalonnage: 2830 kg
 Puissance blocage: de 2120 kg à 4950kg
 Pied mécaniques: 4,3 cm
 Dimensions pneus max: 24"
 Pression de fonct. max: 700 bar





Via del Commercio 15 -37066-Sommacampagna-Verona-ITALY
 TEL: +39 045 8960428 FAX: +39 045 8978641
 E-MAIL: info@pmm-montresor.com
 WEB SITE: www.pmm-montresor.com

MANUFACTURER SINCE 1980

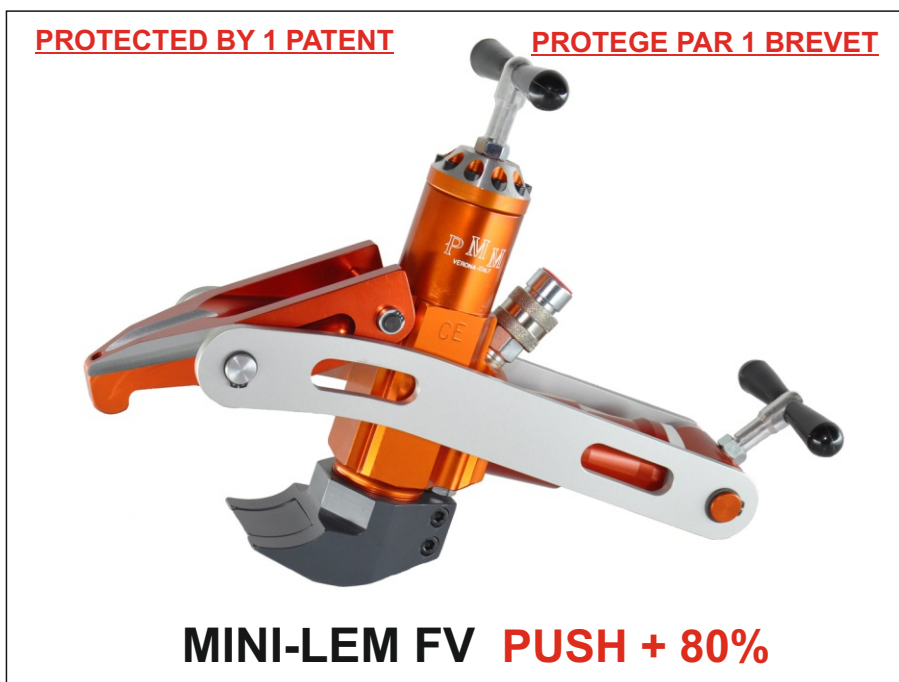

The MINI-LEM **FV** can be used to the inside and outside tyre bead of all types of tyres up to 24": trucks, combine-harvesters and tractors up to 150 HP.

MINI-LEM **FV** est utilisé soit à l'intérieur qu'à l'extérieur du talon des pneus de tout genre jusqu'à 24": camions, moissonneuses-batteuses et tracteurs jusqu'à 150 HP.

Il MINI-LEM **FV** è adatto per stallonare il tallone interno ad esempio di tutti i tipi di pneumatici fino a 24": camion, mietitrebbia e trattori fino a 150 HP.

Characteristics

Weight: 8,7 kg
 Dimensions: 50x11x32 cm
 Stem stroke: **10 cm**
 Bead breaking power: **4900 kg**
 Clamping power: **from 3500kg** to 4950kg
 Foot mechanical: 4,3 cm
 Max. dimensions of tyres: 24"
 Max. operating pressure: 700 bar

Caractéristiques

Poids: 8,7 kg
 Dimensions: 50x11x32 cm
 Course de détalannage: **10 cm**
 Puissance détalonnage: **4900 kg**
 Puissance blocage: **de 3500 kg** à 4950kg
 Pied mécaniques: 4,3 cm
 Dimensions pneus max: 24"
 Pression de fonct. max: 700 bar

Caratteristiche

Peso attrezzo: 8,7 kg
 Dimensioni attrezzo: 50x11x32 cm
 Corsa stelo stallonatore: **10 cm**
 Potenza stallonatura: **4900 kg**
 Potenza bloccaggio: **da 3500kg** a 4950kg
 Lunghezza piedino: 4,3 cm
 Dimensioni pneumatici max: 24"
 Pressione di esercizio max: 700 bar



MADE IN ITALY





Via del Commercio 15 -37066-Sommacampagna-Verona-ITALY
 TEL: +39 045 8960428 FAX: +39 045 8978641
 E-MAIL: info@pmm-montresor.com
 WEB SITE: www.pmm-montresor.com

MANUFACTURER SINCE 1980

PROTECTED BY 1 PATENT

PROTEGE PAR 1 BREVET



MINI-LEM SPECIAL F

The MINI-LEM **SPECIAL F** can be used to the inside and outside tyre bead of all types of tyres up to 25": trucks, combine-harvesters and tractors up to 150 HP.

MINI-LEM **SPECIAL F** est utilisé soit à l'intérieur qu'à l'extérieur du talon des pneus de tout genre jusqu'à 25": camions, moissonneuses-batteuses et tracteurs jusqu'à 150 HP.

Il MINI-LEM **SPECIAL F** è adatto per stallonare il tallone interno ad esempio di tutti i tipi di pneumatici fino a 25": camion, mietitrebbia e trattori fino a 150 HP.

Characteristics

Weight: 8,8 kg
 Dimensions: 50x11x32 cm
 Stem stroke: **10 cm**
 Bead breaking power: 2830 kg
 Clamping power: from 2120kg to 4950kg
 Foot mechanical: **6 cm**
 Max. dimensions of tyres: 25"
 Max. operating pressure: 700 bar

Caractéristiques

Poids: 8,8 kg
 Dimensions: 50x11x32 cm
 Course de détalannage: **10 cm**
 Puissance détalonnage: 2830 kg
 Puissance blocage: de 2120 kg à 4950kg
 Pied mécaniques: **6 cm**
 Dimensions pneus max: 25"
 Pression de fonct. max: 700 bar

Caratteristiche

Peso attrezzo: 8,8 kg
 Dimensioni attrezzo: 50x11x32 cm
 Corsa stelo stallonatore: **10 cm**
 Potenza stallonatura: 2830 kg
 Potenza bloccaggio: da 2120kg a 4950kg
 Lunghezza piedino: **6 cm**
 Dimensioni pneumatici max: 25"
 Pressione di esercizio max: 700 bar



MADE IN ITALY





Via del Commercio 15 -37066-Sommacampagna-Verona-ITALY
 TEL: +39 045 8960428 FAX: +39 045 8978641
 E-MAIL: info@pmm-montresor.com
 WEB SITE: www.pmm-montresor.com

MANUFACTURER SINCE 1980

PROTECTED BY 2 PATENT

PROTEGE PAR 2 BREVET



MINI-LEM SPECIAL FV PUSH + 80%

The MINI-LEM **SPECIAL FV** can be used to the inside and outside tyre bead of all types of tyres up to 25": trucks, combine-harvesters and tractors up to 150 HP.

MINI-LEM **SPECIAL FV** est utilisé soit à l'intérieur qu'à l'extérieur du talon des pneus de tout genre jusqu'à 25": camions, moissonneuses-batteuses et tracteurs jusqu'à 150 HP.

Il MINI-LEM **SPECIAL FV** è adatto per stallonare il tallone interno ad esempio di tutti i tipi di pneumatici fino a 25": camion, mietitrebbia e trattori fino a 150 HP.

Characteristics

Weight: 8,8 kg
 Dimensions: 50x11x32 cm
 Stem stroke: **10 cm**
 Bead breaking power: **4900 kg**
 Clamping power: **from 3500kg** to 4950kg
 Foot mechanical: **6 cm**
 Max. dimensions of tyres: 25"
 Max. operating pressure: 700 bar

Caractéristiques

Poids: 8,8 kg
 Dimensions: 50x11x32 cm
 Course de détalannage: **10 cm**
 Puissance détalonnage: **4900 kg**
 Puissance blocage: **de 3500 kg** à 4950kg
 Pied mécaniques: **6 cm**
 Dimensions pneus max: 25"
 Pression de fonct. max: 700 bar

Caratteristiche

Peso attrezzo: 8,8 kg
 Dimensioni attrezzo: 50x11x32 cm
 Corsa stelo stallonatore: **10 cm**
 Potenza stallonatura: **4900 kg**
 Potenza bloccaggio: **da 3500kg** a 4950kg
 Lunghezza piedino: **6 cm**
 Dimensioni pneumatici max: 25"
 Pressione di esercizio max: 700 bar



MADE IN ITALY





Via del Commercio 15 -37066-Sommacampagna-Verona-ITALY
 TEL: +39 045 8960428 FAX: +39 045 8978641
 E-MAIL: info@pmm-montresor.com
 WEB SITE: www.pmm-montresor.com

MANUFACTURER SINCE 1980

PROTECTED BY 2 PATENT

PROTEGE PAR 2 BREVET



MINI-LEM SPECIAL FV BS/50 PUSH + 80%

The MINI-LEM **SPECIAL FV BS/50** can be used to the inside and outside tyre bead of all types of tyres up to 25": trucks, combine-harvesters and tractors up to 150 HP.

MINI-LEM **SPECIAL FV BS/50** est utilisé soit à l'intérieur qu'à l'extérieur du talon des pneus de tout genre jusqu'à 25": camions, moissonneuses-batteuses et tracteurs jusqu'à 150 HP.

Il MINI-LEM **SPECIAL FV BS/50** è adatto per stallonare il tallone interno ad esempio di tutti i tipi di pneumatici fino a 25": camion, mietitrebbia e trattori fino a 150 HP.

Characteristics

Weight: 9.5 kg
 Dimensions: 50x11x32 cm
 Stem stroke: **10 cm**
 Bead breaking power: **4900 kg**
 Clamping power: **from 3500kg** to 4950kg
 Foot mechanical: **6 cm**
 Max. dimensions of tyres: 25"
 Max. operating pressure: 700 bar

Caractéristiques

Poids: 9.5 kg
 Dimensions: 50x11x32 cm
 Course de détalannage: **10 cm**
 Puissance détalonnage: **4900 kg**
 Puissance blocage: **de 3500kg** to 4950kg
 Pied mécaniques: **6 cm**
 Dimensions pneus max: 25"
 Pression de fonct. max: 700 bar

Caratteristiche

Peso attrezzo: 9.5 kg
 Dimensioni attrezzo: 50x11x32 cm
 Corsa stelo stallonatore: **10 cm**
 Potenza stallonatura: **4900 kg**
 Potenza bloccaggio: **da 3500kg** a 4950kg
 Lunghezza piedino: **6 cm**
 Dimensioni pneumatici max: 25"
 Pressione di esercizio max: 700 bar



MADE IN ITALY





Via del Commercio 15 -37066-Sommacampagna-Verona-ITALY
 TEL: +39 045 8960428 FAX: +39 045 8978641
 E-MAIL: info@pmm-montresor.com
 WEB SITE: www.pmm-montresor.com

MANUFACTURER SINCE 1980

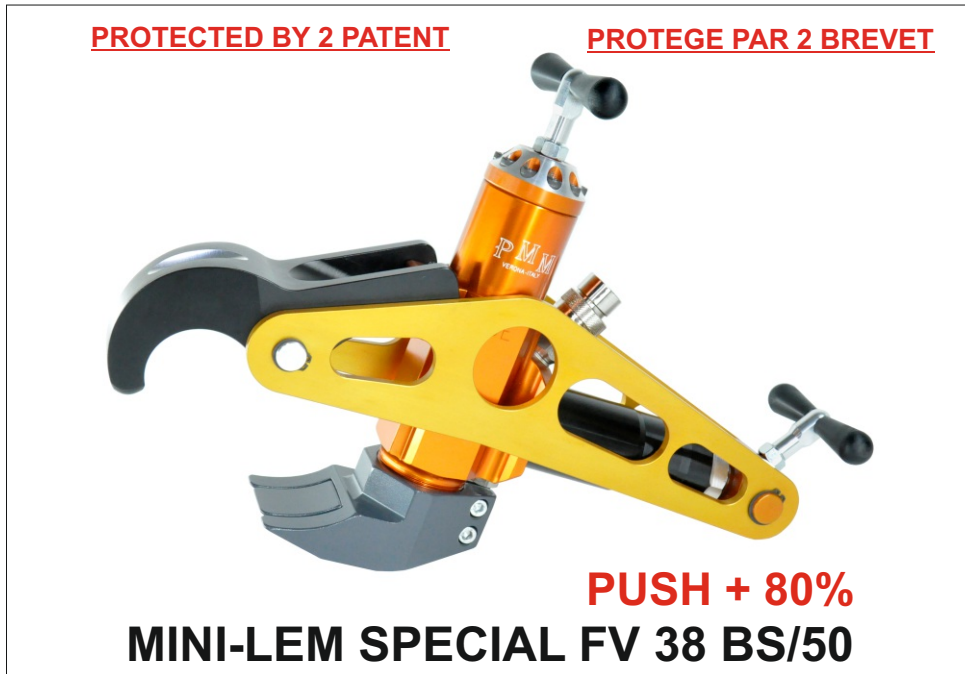

PROTECTED BY 2 PATENT

PROTEGE PAR 2 BREVET

PUSH + 80%

MINI-LEM SPECIAL FV 38 BS/50

The MINI-LEM **SPECIAL FV 38 BS/50** can be used to the inside and outside tyre bead of all types of tyres up to 25": trucks, combine-harvesters and tractors up to 150 HP.

MINI-LEM **SPECIAL FV 38 BS/50** est utilisé soit à l'intérieur qu'à l'extérieur du talon des pneus de tout genre jusqu'à 25": camions, moissonneuses-batteuses et tracteurs jusqu'à 150 HP.

Il MINI-LEM **SPECIAL FV 38 BS/50** è adatto per stallonare il tallone interno ad esempio di tutti i tipi di pneumatici fino a 25": camion, mietitrebbia e trattori fino a 150 HP.

Characteristics

Weight: 9.5 kg
 Dimensions: 50x11x32 cm
 Stem stroke: **10 cm**
 Bead breaking power: **4900 kg**
 Clamping power: **from 5500kg to 7930kg**
 Foot mechanical: **6 cm**
 Max. dimensions of tyres: 25"
 Max. operating pressure: 700 bar

Caractéristiques

Poids: 9.5 kg
 Dimensions: 50x11x32 cm
 Course de détalannage: **10 cm**
 Puissance détalonnage: **4900 kg**
 Puissance blocage: **de 5500 kg à 7930kg**
 Pied mécaniques: **6 cm**
 Dimensions pneus max: 25"
 Pression de fonct. max: 700 bar

Caratteristiche

Peso attrezzo: 9.5 kg
 Dimensioni attrezzo: 50x11x32 cm
 Corsa stelo stallonatore: **10 cm**
 Potenza stallonatura: **4900 kg**
 Potenza bloccaggio: **da 5500kg a 7930kg**
 Lunghezza piedino: **6 cm**
 Dimensioni pneumatici max: 25"
 Pressione di esercizio max: 700 bar



MADE IN ITALY





 **MADE IN ITALY**

Via del Commercio 15 -37066-Sommacampagna-Verona-ITALY
 TEL: +39 045 8960428 FAX: +39 045 8978641
 E-MAIL: info@pmm-montresor.com
 WEB SITE: www.pmm-montresor.com

MANUFACTURER SINCE 1980



The MICRO-LEM can be used to detach the tyres of all type of jeeps, 4x4, cars, trucks without anti-breaking edge and tractors up to 70 HP.

MICRO-LEM est utilisé pour décoller les pneus de tout genre de jeeps, 4x4, voitures, camions sans le bord anti rupture et tracteurs jusqu'à 70 HP.

Il MICRO-LEM è adatto per stallonare i pneumatici di tutti i tipi di jeep, fuoristrada, vetture, camion senza bordo anti stallonamento e trattori fino a 70 HP.

Characteristics

Weight: 5 kg
 Dimensions: 17x17x17 cm
 Stem stroke: 4 cm
 Bead breaking power: 2830 kg
 Clamping power: from 760 kg to 1780 kg
 Foot mechanical: 3,5 cm
 Max. dimensions of tyres:*
 *All types of rims with low edge
 Max. operating pressure: 700 bar

Caratteristiche

Peso attrezzo: 5 kg
 Dimensioni attrezzo: 17x17x17 cm
 Corsa stelo stallonatore: 4 cm
 Potenza stallonatura: 2830 kg
 Potenza bloccaggio: da 760 kg a 1780 kg
 Lunghezza piedini: 3,5 cm
 Dimensioni pneumatici max:*
 *Tutti i cerchi a bordo basso
 Pressione di esercizio max: 700 bar

Caractéristiques

Poids: 5 kg
 Dimensions: 17x17x17 cm
 Course de détalonnage: 4 cm
 Puissance détalonnage: 2830 kg
 Puissance blocage: de 760 kg à 1780 kg
 Pied mécaniques: 3,5 cm
 Dimensions pneus max:*
 *Toutes les jantes avec bord bas
 Pression de fonct. max: 700 bar





Via del Commercio 15 -37066-Sommacampagna-Verona-ITALY
 TEL: +39 045 8960428 FAX: +39 045 8978641
 E-MAIL: info@pmm-montresor.com
 WEB SITE: www.pmm-montresor.com

MANUFACTURER SINCE 1980

PROTECTED BY 1 PATENT

PROTEGE PAR 1 BREVET



MICRO-LEM V PUSH + 80%

The MICRO-LEM V can be used to detach the tyres of all type of jeeps, 4x4, cars, trucks without anti-breaking edge and tractors up to 70 HP.

MICRO-LEM V est utilisé pour décoller les pneus de tout genre de jeeps, 4x4, voitures, camions sans le bord anti rupture et tracteurs jusqu'à 70 HP.

Il MICRO-LEM V è adatto per stallonare i pneumatici di tutti i tipi di jeep, fuoristrada, vetture, camion senza bordo anti stallonamento e trattori fino a 70 HP.

Characteristics

Weight: 5 kg
 Dimensions: 17x17x17 cm
 Stem stroke: 4 cm
 Bead breaking power: **4900 kg**
 Clamping power: **from 1200 kg** to 1780 kg
 Foot mechanical: 3,5 cm
 Max. dimensions of tyres: *
 *All types of rims with low edge
 Max. operating pressure: 700 bar

Caractéristiques

Poids: 5 kg
 Dimensions: 17x17x17 cm
 Course de détalonnage: 4 cm
 Puissance détalonnage: **4900 kg**
 Puissance blocage: **de 1200 kg** à 1780 kg
 Pied mécaniques: 3,5 cm
 Dimensions pneus max: *
 *Toutes les jantes avec bord bas
 Pression de fonct. max: 700 bar

Caratteristiche

Peso attrezzo: 5 kg
 Dimensioni attrezzo: 17x17x17 cm
 Corsa stelo stallonatore: 4 cm
 Potenza stallonatura: **4900 kg**
 Potenza bloccaggio: **da 1200 kg** a 1780 kg
 Lunghezza piedini: 3,5 cm
 Dimensioni pneumatici max: *
 *Tutti i cerchi a bordo basso
 Pressione di esercizio max: 700 bar



MADE IN ITALY





Via del Commercio 15 -37066-Sommacampagna-Verona-ITALY
 TEL: +39 045 8960428 FAX: +39 045 8978641
 E-MAIL: info@pmm-montresor.com
 WEB SITE: www.pmm-montresor.com

MANUFACTURER SINCE 1980

PROTECTED BY 1 PATENT

PROTEGE PAR 1 BREVET



MICRO-LEM SUPER PUSH + 80%

The MICRO-LEM SUPER can be used to detach the tyres of all type of jeeps, 4x4, cars, trucks without anti-breaking edge and tractors up to 70 HP.

MICRO-LEM SUPER est utilisé pour décoller les pneus de tout genre de jeeps, 4x4, voitures, camions sans le bord anti rupture et tracteurs jusqu'à 70 HP.

Il MICRO-LEM SUPER è adatto per stallonare i pneumatici di tutti i tipi di jeep, fuoristrada, vetture, camion senza bordo anti stallonamento e trattori fino a 70 HP.

Characteristics

Weight: 5,5 kg
 Dimensions: 22x22x23 cm
 Stem stroke: **7 cm**
 Bead breaking power: **4900 kg**
 Clamping power: **from 1600kg to 2200kg**
 Foot mechanical: 3,5 cm
 Max. dimensions of tyres: *
 *All types of rims with low edge
 Max. operating pressure: 700 bar

Caractéristiques

Poids: 5,5 kg
 Dimensions: 22x22x23 cm
 Course de détalonnage: **7 cm**
 Puissance détalonnage: **4900 kg**
 Puissance blocage: **de 1600kg à 2200kg**
 Pied mécaniques: 3,5 cm
 Dimensions pneus max: *
 *Toutes les jantes avec bord bas
 Pression de fonct. max: 700 bar

Caratteristiche

Peso attrezzo: 5,5 kg
 Dimensioni attrezzo: 22x22x23 cm
 Corsa stelo stallonatore: **7 cm**
 Potenza stallonatura: **4900 kg**
 Potenza bloccaggio: **da 1600kg a 2200kg**
 Lunghezza piedini: 3,5 cm
 Dimensioni pneumatici max: *
 *Tutti i cerchi a bordo basso
 Pressione di esercizio max: 700 bar



MADE IN ITALY





Via del Commercio 15 -37066-Sommacampagna-Verona-ITALY
 TEL: +39 045 8960428 FAX: +39 045 8978641
 E-MAIL: info@pmm-montresor.com
 WEB SITE: www.pmm-montresor.com

MANUFACTURER SINCE 1980

PROTECTED BY 1 PATENT PROTEGE PAR 1 BREVET



SHUTTLE-8 SP



The SHUTTLE-8 SP can be used to detach bead of the tyres of all types of rims in five pieces which have the proper anchoring seat on both sides, from 25" to 51". this type of rims are commonly used on big and medium-sized caterpillars.

SHUTTLE-8 SP est utilisé pour décoller le talon des pneus de tout genre aux jantes à 5 pièces qui ont le bon ancrage des deux côtés de 25" à 51".

Ce type de jantes sont communément utilisés sur les grandes et moyennes chenilles.

Lo SHUTTLE-8 SP è adatto a stallonare il tallone dei pneumatici con qualunque tipo di cerchioni da 5 pezzi dotati del corretto punto di attacco su ambo i lati, da 25" a 51".

Questo tipo di cerchioni è comunemente utilizzato su caterpillar di medie e grandi dimensioni

Characteristics

Weight: 6,8 kg
 Dimensions: Ø13x44 cm
 Stem stroke: 8 cm
 Bead breaking power: 13.700 kg
 Max. dimensions of tyres: 25" to 51"
 Max. operating pressure: 700 bar

Caractéristiques

Poids: 6,8 kg
 Dimensions: Ø13x44 cm
 Course de détalonnage: 8 cm
 Puissance détalonnage: 13.700 kg
 Dimensions pneus max: 25" a 51"
 Pression de fonct. max: 700 bar

Caratteristiche

Peso attrezzo: 6,8 kg
 Dimensione attrezzo: Ø13x44 cm
 Corsa stelo stallonatore: 8 cm
 Potenza stallonatura: 13.700 kg
 Dimensioni pneumatici max: 25" a 51"
 Pressione di esercizio max: 700 bar





Via del Commercio 15 -37066-Sommacampagna-Verona-ITALY
 TEL: +39 045 8960428 FAX: +39 045 8978641
 E-MAIL: info@pmm-montresor.com
 WEB SITE: www.pmm-montresor.com

MANUFACTURER SINCE 1980



The SHUTTLE-13 SP can be used to detach bead of the tyres of all types of rims in five pieces which have the proper anchoring seat on both sides, from 25" to 51". this type of rims are commonly used on big and medium-sized caterpillars.

SHUTTLE-13 SP est utilisé pour décoller le talon des pneus de tout genre aux jantes à 5 pièces qui ont le bon ancrage des deux côtés de 25" à 51".
 Ce type de jantes sont communément utilisés sur les grandes et moyennes chenilles.

Lo SHUTTLE-13 SP è adatto a stallonare il tallone dei pneumatici con qualunque tipo di cerchioni da 5 pezzi dotati del corretto punto di attacco su ambo i lati, da 25" a 51".
 Questo tipo di cerchioni è comunemente utilizzato su caterpillar di medie e grandi dimensioni

Characteristics

Weight: 7,8 kg
 Dimensions: Ø13x54 cm
 Stem stroke: 13 cm
 Bead breaking power: 13.700 kg
 Max. dimensions of tyres: 25" to 51"
 Max. operating pressure: 700 bar

Caractéristiques

Poids: 7,8 kg
 Dimensions: Ø13x54 cm
 Course de détalonnage: 13 cm
 Puissance détalonnage: 13.700 kg
 Dimensions pneus max: 25" a 51"
 Pression de fonct. max: 700 bar

Caratteristiche

Peso attrezzo: 7,8 kg
 Dimensione attrezzo: Ø13x54 cm
 Corsa stelo stallonatore: 13 cm
 Potenza stallonatura: 13.700 kg
 Dimensioni pneumatici max: 25" a 51"
 Pressione di esercizio max: 700 bar





Via del Commercio 15 -37066-Sommacampagna-Verona-ITALY
 TEL: +39 045 8960428 FAX: +39 045 8978641
 E-MAIL: info@pmm-montresor.com
 WEB SITE: www.pmm-montresor.com

MANUFACTURER SINCE 1980

PROTECTED BY 1 PATENT
PROTEGE PAR 1 BREVET



MAXI SHUTTLE 13 SP

The MAXI SHUTTLE-13 SP can be used to detach bead of the tyres of all types of rims in 5/7 pieces which have the proper anchoring seat on both sides, from 49" to 63".

MAXI SHUTTLE-13 SP est utilisé pour décoller le talon des pneus de tout genre aux jantes à 5/7 pièces qui ont le bon ancrage des deux côtés de 49" à 63"

Il MAXI SHUTTLE-13 SP è adatto a stallonare il tallone dei pneumatici con qualunque tipo di cerchioni da 5/7 pezzi dotati del corretto punto di attacco su ambo i lati, da 49" a 63".

Characteristics

Weight: 14,5 kg
 Dimensions: ØMax.22x63 cm
 Stem stroke: 13 cm
 Bead breaking power: **20.000 kg**
 Max. dimensions of tyres: **49" to 63"**
 Max. operating pressure: 700 bar

Caractéristiques

Poids: 14,5 kg
 Dimensions: ØMax.22x63 cm
 Course de détalonnage: 13 cm
 Puissance détalonnage: **20.000 kg**
 Dimensions pneus max: **49" a 63"**
 Pression de fonct. max: 700 bar

Caratteristiche

Peso attrezzo: 14,5 kg
 Dimensione attrezzo: ØMax.22x63 cm
 Corsa stelo stallonatore: 13 cm
 Potenza stallonatura: **20.000 kg**
 Dimensioni pneumatici max: **49" a 63"**
 Pressione di esercizio max: 700 bar



MADE IN ITALY





Via del Commercio 15 -37066-Sommacampagna-Verona-ITALY
 TEL: +39 045 8960428 FAX: +39 045 8978641
 E-MAIL: info@pmm-montresor.com
 WEB SITE: www.pmm-montresor.com

MANUFACTURER SINCE 1980

PROTECTED BY 1 PATENT

PROTEGE PAR 1 BREVET



VIKING 2.7+PUMP



Characteristics

Weight: 1,5 kg
 Dimensions: Ø8x9 cm
 Stem stroke: 2,7 cm
 Bead breaking power: 7.000 kg
 Max. operating pressure: 400 bar
 Extensions:
 N°1 Ø7 h=80mm - 0,8 kg
 N°1 Ø7 h=50mm - 0,55 kg
 N°1 Ø7 h=35mm - 0,4 kg

Pump characteristics

Weight: 4,9 kg
 Dimensions: 43x14,5x10,5 cm
 Max. pressure: 400 bar

Caractéristiques

Poids: 1,5 kg
 Dimensions: Ø8x9 cm
 Corse de détalonnage: 2,7 cm
 Puissance détalonnage: 7.000 kg
 Pression de fonct. max: 400 bar
 Extensions:
 N°1 Ø7 h=80mm - 0,8 kg
 N°1 Ø7 h=50mm - 0,55 kg
 N°1 Ø7 h=35mm - 0,4 kg

Caractéristiques de la pompe

Poids: 4,9 kg
 Dimensions: 43x14,5x10,5 cm
 Pression max: 400 bar

Caratteristiche

Peso attrezzo: 1,5 kg
 Dimensioni attrezzo: Ø8x9 cm
 Corsa stelo stallonatore: 2,7 cm
 Potenza stallonatura: 7.000 kg
 Pressione di esercizio max: 400 bar
 Prolunghe:
 N°1 Ø7 h=80mm - 0,8 kg
 N°1 Ø7 h=50mm - 0,55 kg
 N°1 Ø7 h=35mm - 0,4 kg

Caratteristiche pompa

Peso pompa: 4,9 kg
 Misure: 43x14,5x10,5 cm
 Pressione max: 400 bar



MADE IN ITALY





Via del Commercio 15 -37066-Sommacampagna-Verona-ITALY
 TEL: +39 045 8960428 FAX: +39 045 8978641
 E-MAIL: info@pmm-montresor.com
 WEB SITE: www.pmm-montresor.com

MANUFACTURER SINCE 1980



VIKING 4 MAGNETIC

The VIKING-4 is a tool which acts on the inner part of the rim. It leans on the chassis of the machine and pushes the ring of the rim which removes the tyre from its seat. It can be used with rims in three and five pieces, mounted on earth-moving machines from 25" to 51". It is delivered with 5 extensions (one of 100 mm, two of 50 mm each and 2 of 25 mm each) as standard accessories.

VIKING-4 est un outil utilisé sur l'intérieure de la jante. il appuie sur la châssis de la machine et pousse la bague de la jante qui enlève le pneu de son siège. On peut l'utiliser sur les jantes de 3 à 5, pièces montées sur les engins de terrassement de 25" à 51". Il est fourni avec 5 allonges (une de 100mm, deux de 50 mm et deux de 25 mm) en tant d'accessoires standards.

Il VIKING-4 è un attrezzo che lavora nella parte interna del cerchio. Si appoggia al telaio della macchina e spinge l'anello del cerchio il quale a sua volta stallona il pneumatico dalla sua sede. Questo attrezzo viene utilizzato su cerchioni sia a 3 pezzi che a 5 pezzi, di macchine movimento terra che vanno da 25" a 51". In dotazione ha 5 prolunghe (una da 100 mm, due da 50 mm e 2 da 25 mm).

Characteristics

Weight: 3,0 kg
 Dimensions: Ø9x17 cm
 Stem stroke: 4 cm
 Bead breaking power: 19.800 kg
 Max. dimensions of tyres: 51"
 Max. operation pressure: 700 bar

Caractéristique

Poids: 3,0 kg
 Dimensions: Ø9x17 cm
 Course de détalonnage: 4 cm
 Puissance détalonnage: 19.800 kg
 Dimensions pneus max: 51"
 Pression de fonct. max: 700 bar

Caratteristiche

Peso attrezzo: 3,0 kg
 Dimensioni attrezzo: Ø9x17 cm
 Corsa stelo stallonatore: 4 cm
 Potenza stallonatura: 19.800 kg
 Dimensioni pneumatici max: 51"
 Pressione di esercizio max: 700 bar



MADE IN ITALY





Via del Commercio 15 -37066-Sommacampagna-Verona-ITALY
 TEL: +39 045 8960428 FAX: +39 045 8978641
 E-MAIL: info@pmm-montresor.com
 WEB SITE: www.pmm-montresor.com

MANUFACTURER SINCE 1980



The VIKING-8 is a tool which acts on the inner part of the rim. It leans on the chassis of the machine and pushes the ring of the rim which removes the tyre from its seat. It can be used with rims in three and five pieces, mounted on earth-moving machines from 25" to 51".

VIKING-8 est un outil utilisé sur l'intérieure de la jante. il appuie sur la châssis de la machine et pousse la bague de la jante qui enlève le pneu de son siège. On peut l'utiliser sur les jantes de 3 à 5 pièces montées sur les engins de terrassement de 25" à 51".

Il VIKING-8 è un attrezzo che lavora nella parte interna del cerchio. Si appoggia al telaio della macchina e spinge l'anello del cerchio il quale a sua volta stallona il pneumatico dalla sua sede. Questo attrezzo viene utilizzato su cerchioni sia a 3 pezzi che a 5 pezzi, di macchine movimento che vanno da 25" a 51".

Characteristics

Weight: 3,7 kg
 Dimensions: Ø8x18 cm
 Stem stroke: 8 cm
 Bead breaking power: 13.700 kg
 Max. dimensions of tyres: 51"
 Max. operating pressure: 700 bar

Caractéristique

Poids: 3,7 kg
 Dimensions: Ø8x18 cm
 Corse de détalonnage: 8 cm
 Puissance détalonnage: 13.700 kg
 Dimensions pneus max: 51"
 Pression de fonct. max: 700 bar

Caratteristiche

Peso attrezzo: 3,7 kg
 Dimensioni attrezzo: Ø8x18 cm
 Corsa stelo stallonatore: 8 cm
 Potenza stallonatura: 13.700 kg
 Dimensioni pneumatici max: 51"
 Pressione di esercizio max: 700 bar



MADE IN ITALY





Via del Commercio 15 -37066-Sommacampagna-Verona-ITALY
TEL: +39 045 8960428 FAX: +39 045 8978641
E-MAIL: info@pmm-montresor.com
WEB SITE: www.pmm-montresor.com

MANUFACTURER SINCE 1980



VIKING 13

The VIKING-13 is a tool which acts on the inner part of the rim. It leans on the chassis of the machine and pushes the ring of the rim which removes the tyre from its seat. It can be used with rims in three and five pieces, mounted on earth-moving machines from 25" to 51".

VIKING-13 est un outil utilisé sur l'intérieure de la jante. Il appuie sur la châssis de la machine et pousse la bague de la jante qui enlève le pneu de son siège. On peut l'utiliser sur les jantes de 3 à 5 pièces, montées sur les engins de terrassement de 25" à 51".

Il VIKING-13 è un attrezzo che lavora nella parte interna del cerchio. Si appoggia al telaio della macchina e spinge l'anello del cerchio il quale a sua volta stacca il pneumatico dalla sua sede. Questo attrezzo viene utilizzato su cerchioni sia a 3 pezzi che a 5 pezzi, di macchine movimento che vanno da 25" a 51".

Characteristics

Weight: 4,5 kg
Dimensions: Ø8x23 cm
Stem stroke: 13 cm
Bead breaking power: 13.700 kg
Max. dimensions of tyres: 51"
Max. operating pressure: 700 bar

Caractéristique

Poids: 4,5 kg
Dimensions: Ø8x23 cm
Corse de détalonnage: 13 cm
Puissance détalonnage: 13.700 kg
Dimensions pneus max: 51"
Pression de fonct. max: 700 bar

Caratteristiche

Peso attrezzo: 4,5 kg
Dimensioni attrezzo: Ø8x23 cm
Corsa stelo stallonatore: 13 cm
Potenza stallonatura: 13.700 kg
Dimensioni pneumatici max: 51"
Pressione di esercizio max: 700 bar



MADE IN ITALY





Via del Commercio 15 -37066-Sommacampagna-Verona-ITALY
 TEL: +39 045 8960428 FAX: +39 045 8978641
 E-MAIL: info@pmm-montresor.com
 WEB SITE: www.pmm-montresor.com

MANUFACTURER SINCE 1980



This KIT is to extend VIKING-8 and VIKING-13, extensions are magnetic in light league of various measures.

Le KIT est fourni pour allonger le VIKING-8 et le VIKING-13, les allonges sont aimantées, en alliage léger et de différentes longueurs.

Questo KIT è necessario per allungare il VIKING-8 e il VIKING-13, le prolunghe sono magnetiche in lega leggera di varie misure.

Supplied

- N°1 adaptor
- N°1 a 10 cm extension
- N°2 a 5 cm extensions
- N°2 a 2,5 cm extensions

Fourni

- N°1 adaptateur
- N°1 extension de 10cm
- N°2 extensions de 5cm
- N°2 extensions de 2,5cm

Dotazione

- N°1 adattatore
- N°1 prolunga da 10 cm
- N°2 prolunghe da 5 cm
- N°2 prolunghe da 2,5 cm



MADE IN ITALY





Via del Commercio 15 -37066-Sommacampagna-Verona-ITALY
 TEL: +39 045 8960428 FAX: +39 045 8978641
 E-MAIL: info@pmm-montresor.com
 WEB SITE: www.pmm-montresor.com

MANUFACTURER SINCE 1980



MANTIS HD F



MANTIS HD F is an equipment purposely designed for breaking tyres from rims of trucks, in particular of modern ones with anti bead breaking edge.

MANTIS HD F est un outil spécialement conçu pour détalonner les pneus des jantes des camions, en particulier des camions modernes fournis du bord anti détalonnage.

MANTIS HD F è un attrezzo appositamente creato per stallonare i pneumatici dai cerchioni dei cammion, in particolare quelli dotati di bordo anti-stallonamento

Characteristics

Weight: 10 kg
 Dimensions: 74x12x43 cm
 Stem stroke: 11,5 cm
 Bead breaking power: 4900 kg
 Max. dimensions of tyres:
 Truck and bus
 Max. operating pressure: 700 bar

Caractéristiques

Poids: 10 kg
 Dimensions: 74x12x43 cm
 Course de détalonnage: 11,5 cm
 Puissance détalonnage: 4900 kg
 Dimensions pneus max:
 Camions et des bus
 Pression de fonct. max: 700 bar

Caratteristiche

Peso attrezzo: 10 kg
 Dimensioni attrezzo: 74x12x43 cm
 Corsa stelo stallonatore: 11,5 cm
 Potenza stallonatura: 4900 kg
 Dimensioni pneumatici max:
 camion e autobus
 Pressione di esercizio max: 700 bar



MADE IN ITALY





Via del Commercio 15 -37066-Sommacampagna-Verona-ITALY
 TEL: +39 045 8960428 FAX: +39 045 8978641
 E-MAIL: info@pmm-montresor.com
 WEB SITE: www.pmm-montresor.com

MANUFACTURER SINCE 1980



MANTIS HD P is an equipment purposely designed for breaking tyres from rims of trucks, in particular of modern ones with anti bead breaking edge.

MANTIS HD P est un outil spécialement conçu pour détalonner les pneus des jantes des camions, en particulier des camions modernes fournis du bord anti détalonnage.

MANTIS HD P è un attrezzo appositamente creato per stallonare i pneumatici dai cerchioni dei cammion, in particolare quelli dotati di bordo anti-stallonamento

Characteristics

Weight: 12 kg
 Dimensions: 74x13,5x33 cm
 Stem stroke: 11,5 cm
 Bead breaking power: 4900 kg
 Max. dimensions of tyres:
 Truck and bus
 Max. operating pressure: 700 bar

Caractéristiques

Poids: 12 kg
 Dimensions: 74x13,5x33 cm
 Course de détalonnage: 11,5 cm
 Puissance détalonnage: 4900 kg
 Dimensions pneus max:
 Camions et des bus
 Pression de fonct. max: 700 bar

Caratteristiche

Peso attrezzo: 12 kg
 Dimensioni attrezzo: 74x13,5x33 cm
 Corsa stelo stallonatore: 11,5 cm
 Potenza stallonatura: 4900 kg
 Dimensioni pneumatici max:
 camion e autobus
 Pressione di esercizio max: 700 bar



MADE IN ITALY





Via del Commercio 15 -37066-Sommacampagna-Verona-ITALY
 TEL: +39 045 8960428 FAX: +39 045 8978641
 E-MAIL: info@pmm-montresor.com
 WEB SITE: www.pmm-montresor.com

MANUFACTURER SINCE 1980



MANTIS 40T

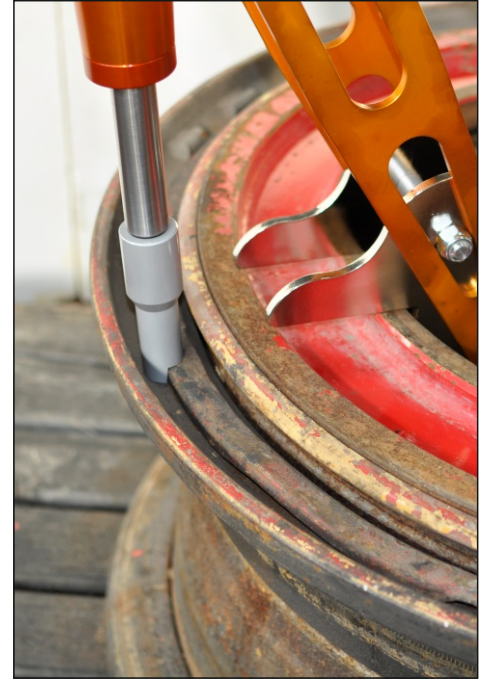

MANTIS 40T is purposely designed for breaking Mod.18-0033 40" crossply tires mounted on cranes and container handling (such as Bellotti, C.V.S., Ferrari).

MANTIS 40T est spécialement conçu pour décoller les pneus Mod. 18-0033 à 40 crossply (pneus à carcasse diagonale) montés sur les grues en général et surtout sur les grues portuaires (voir Bellotti, C.V.S., Ferrari).

MANTIS 40T è studiato appositamente per stallonare il tallone dei pneumatici Mod. 18-0033 da 40 tele montati su gru e porta container (tipo Bellotti, C.V.S., Ferrari).

Characteristics

Weight: 22 kg
 Dimensions: 72x15x72 cm
 Stem stroke: **16 cm**
 Bead breaking power: 4900 kg
 Max. operating pressure: 700 bar

Caractéristiques

Poids: 22 kg
 Dimensions: 75x15x72 cm
 Course de détalonnage: **16 cm**
 Puissance détalonnage: 4900 kg
 Pression de fonct. max: 700 bar

Caratteristiche

Peso attrezzo: 22 kg
 Dimensioni attrezzo: 72x15x72 cm
 Corsa stelo stallonatore: **16 cm**
 Potenza stallonatura: 4900 kg
 Pressione di esercizio max: 700 bar



MADE IN ITALY





DI MONTRESOR GIANFRANCO®

Via del Commercio 15 -37066-Sommacampagna-Verona-ITALY
 TEL: +39 045 8960428 FAX: +39 045 8978641
 E-MAIL: info@pmm-montresor.com
 WEB SITE: www.pmm-montresor.com

MANUFACTURER SINCE 1980

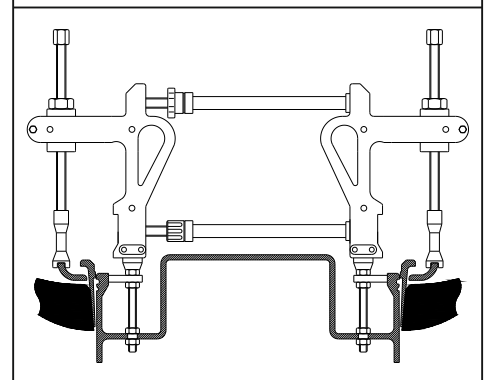
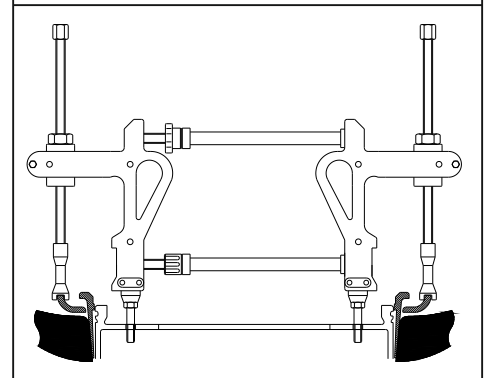
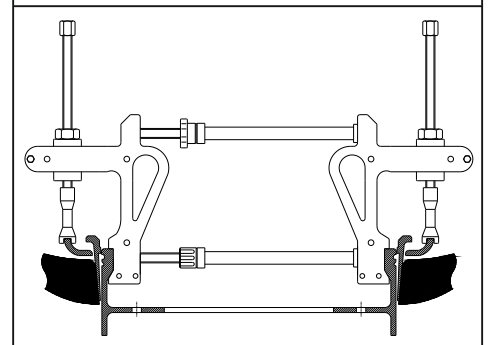
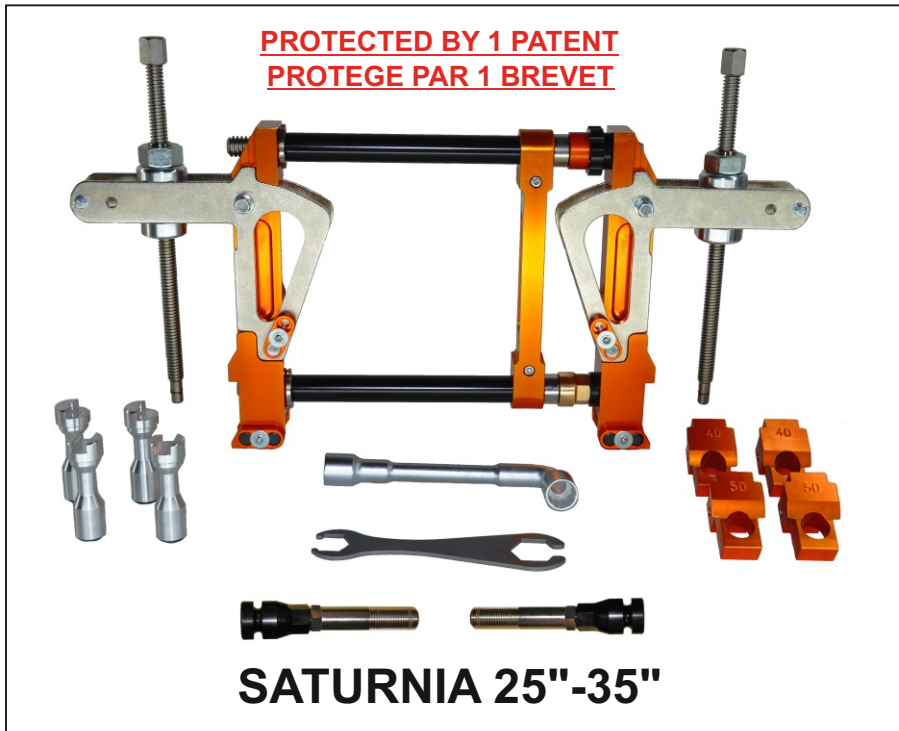

SATURNIA is a conic rings alignment machine for E.M. on 3 and 5 pieces from 25" to 35". Easy assembly of O-Ring and ring stop-seeger. All operations can be performed by an operator only.

SATURNIA est un outil à l'alignement des anneaux coniques pour les engins de terrassement de 3 à 5 pièces de 25" à 35". Montage facile du joint et de la bague de butée. Toute opération peut être faite par un seul opérateur.

SATURNIA è un attrezzo che agisce sull'allineamento degli anelli conici ed è adatto per macchine movimento terra da 3 a 5 pezzi da 25" a 35". Facilita il montaggio della guarnizione di tenuta e dell'anello antiestrusione. Tutte le operazioni possono essere svolte da un solo operatore.

Characteristics

Weight: 10 + 12 kg
 Dimensions: 89x50x9 cm
 Stem stroke: 40 cm
 Bead breaking power: manual
 Clamping power: manual
 Max. dimensions of tyres: from 25" to 35"



Caratteristiche

Peso: 10 + 12 kg
 Dimensioni: 89x50x9 cm
 Corsa stelo stallonatore: 40 cm
 Potenza stallonatura: manuale
 Potenza bloccaggio: manuale
 Dimensioni pneumatici max: da 25" a 35"

Caractéristiques

Poids: 10 + 12 kg
 Dimensions: 89x50x9 cm
 Course de détalonnage: 40 cm
 Puissance détalonnage: manuel
 Puissance blocage: manuel
 Dimensions pneus max: da 25" a 35"





Via del Commercio 15 -37066-Sommacampagna-Verona-ITALY
TEL: +39 045 8960428 FAX: +39 045 8978641
E-MAIL: info@pmm-montresor.com
WEB SITE: www.pmm-montresor.com

MANUFACTURER SINCE 1980

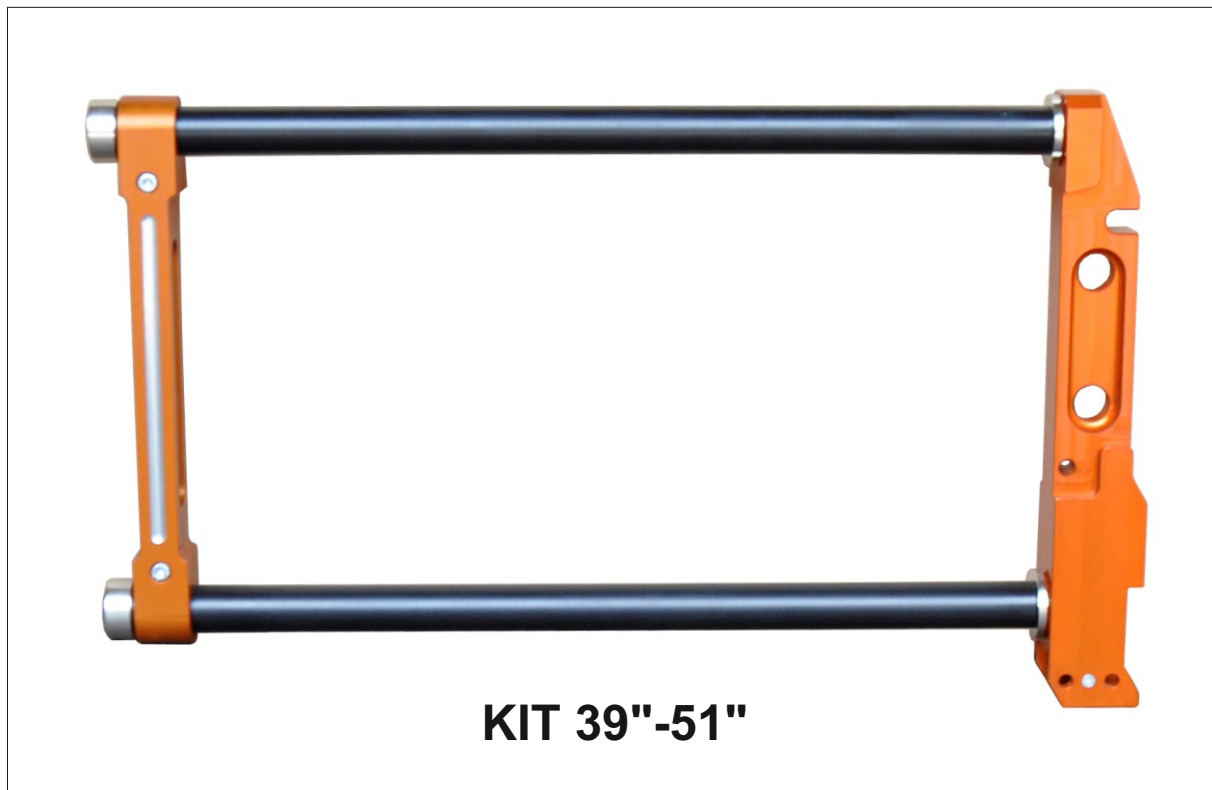

KIT EXTENSIONS 39"/51" FOR SATURNIA

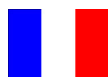

KIT ALLONGE 39"/51" POUR SATURNIA



KIT PROLUNGHE 39"/51" PER SATURNIA



MADE IN ITALY





Via del Commercio 15 -37066-Sommacampagna-Verona-ITALY
 TEL: +39 045 8960428 FAX: +39 045 8978641
 E-MAIL: info@pmm-montresor.com
 WEB SITE: www.pmm-montresor.com

MANUFACTURER SINCE 1980

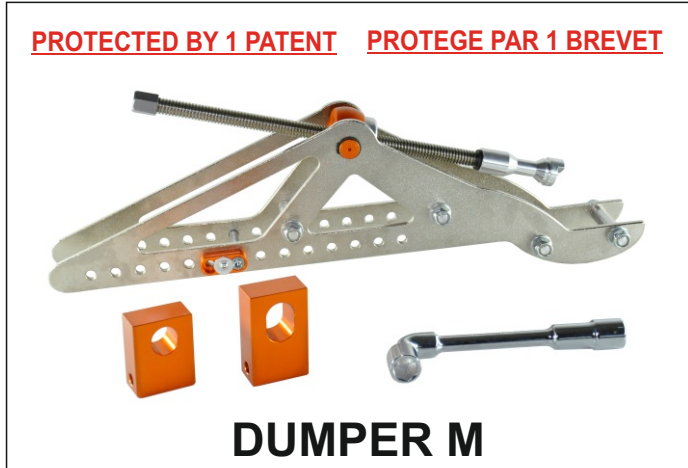

DUMPER M is especially designed for breaking the internal part o Dumper tires without removing the rim.

DUMPER M est surtout conçu pour décoller les pneus Dumper à l'intérieur sans retirer la jante.

DUMPER M è un attrezzo adatto per staccare i pneumatici interni dei Dumper senza dover smontare il cerchio.

Characteristics

Weight: 8,5 kg
 Dimensions: 76x10x24 cm
 Stem stroke: 40 cm
 Bead breaking power: manual
 Max. dimensions of tyres: 35" to 49"

Caractéristiques

Poids: 8,5 kg
 Dimensions: 76x10x24 cm
 Course de détalonnage: 40 cm
 Puissance détalonnage: manuel
 Dimensions pneus max: 35" a 49"

Caratteristiche

Peso attrezzo: 8,5 kg
 Dimensioni attrezzo: 76x10x24 cm
 Corsa stelo stallonatore: 40 cm
 Potenza stallonatura: manuale
 Dimensioni pneumatici max: 35" a 49"



MADE IN ITALY





Via del Commercio 15 -37066-Sommacampagna-Verona-ITALY
 TEL: +39 045 8960428 FAX: +39 045 8978641
 E-MAIL: info@pmm-montresor.com
 WEB SITE: www.pmm-montresor.com

MANUFACTURER SINCE 1980

PROTECTED BY 1 PATENT

PROTEGE PAR 1 BREVET



ZEUS 50



The ZEUS 50 can be used to detach bead of the tyres of all types of rims which have the proper anchoring seat on both sides, from 35" to 63". This type of rims are commonly used on big and medium-sized E.M. vehicles.

ZEUS 50 est utilisé pour décoller le talon des pneus de tout genre de jantes qui ont le bon ancrage des deux côtés de 35" à 63".

Ce type de jantes sont communément utilisés sur les grandes et moyennes terrassements.

IL ZEUS 50 è adatto a stallonare il tallone dei pneumatici con qualunque tipo di cerchioni dotati del corretto punto di attacco su ambo i lati, da 35" a 63".

Questo tipo di cerchioni è comunemente utilizzato su caterpillar di medie e grandi dimensioni.

Characteristics

Weight: 12 kg
 Dimensions: 17x14x41 cm
 Stem stroke: 15 cm
 Bead breaking power: **20.000 kg**
 Max. dimensions of tyres: 35" to 63"
 Max. operating pressure: 700 bar

Caractéristiques

Poids: 12 kg
 Dimensions: 17x14x41 cm
 Course de détalonnage: 15 cm
 Puissance détalonnage: **20.000 kg**
 Dimensions pneus max: 35" a 63"
 Pression de fonct. max: 700 bar

Caratteristiche

Peso attrezzo: 12 kg
 Dimensione attrezzo: 17x14x41 cm
 Corsa stelo stallonatore: 15 cm
 Potenza stallonatura: **20.000 kg**
 Dimensioni pneumatici max: 35" a 63"
 Pressione di esercizio max: 700 bar



MADE IN ITALY





Via del Commercio 15 -37066-Sommacampagna-Verona-ITALY
 TEL: +39 045 8960428 FAX: +39 045 8978641
 E-MAIL: info@pmm-montresor.com
 WEB SITE: www.pmm-montresor.com

MANUFACTURER SINCE 1980

PROTECTED BY 1 PATENT

PROTEGE PAR 1 BREVET



DINA



The **DINA** can be used to detach bead of the tyres of all types of rims which have the proper anchoring seat on both sides, from 35" to 63". This type of rims are commonly used on big and medium-sized E.M. vehicles and 6 pieces Titan SVM-OVM 63".

DINA est utilisé pour décoller le talon des pneus de tout genre de jantes qui ont le bon ancrage des deux côtés de 35" à 63". Ce type de jantes sont communément utilisés sur les grandes et moyennes terrassements et 6 pièces Titan SVM-OVM 63".

IL **DINA** è adatto a stallonare il tallone dei pneumatici con qualunque tipo di cerchi dotati del corretto punto di attacco su ambo i lati, da 35" a 63". Questo tipo di cerchi è comunemente utilizzato su caterpillar e cerchi a 6 pezzi Titan SVM-OVM 63"

Characteristics

Weight: 17,5 kg
 Dimensions: 19x19x45 cm
 Stem stroke: 15 cm
 Bead breaking power: **27.000 kg**
 Max. dimensions of tyres: 35" to 63"
 Max. operating pressure: 700 bar

Caractéristiques

Poids: 17,5 kg
 Dimensions: 19x19x45 cm
 Course de détalonnage: 15 cm
 Puissance détalonnage: **27.000 kg**
 Dimensions pneus max: 35" a 63"
 Pression de fonct. max: 700 bar

Caratteristiche

Peso attrezzo: 17,5 kg
 Dimensione attrezzo: 19x19x45 cm
 Corsa stelo stallonatore: 15 cm
 Potenza stallonatura: **27.000 kg**
 Dimensioni pneumatici max: 35" a 63"
 Pressione di esercizio max: 700 bar





Via del Commercio 15 -37066-Sommacampagna-Verona-ITALY
 TEL: +39 045 8960428 FAX: +39 045 8978641
 E-MAIL: info@pmm-montresor.com
 WEB SITE: www.pmm-montresor.com

MANUFACTURER SINCE 1980

PROTECTED BY 1 PATENT

PROTEGE PAR 1 BREVET



TEREX



The TEREX is purposely created to remove the rim from the hub of the Dumper.

Le TEREX est conçu pour retirer la jante du moyeu des Dumper.

Il TEREX serve per staccare il cerchio dal mozzo dei DUMPER.

Characteristics

Weight: 16 kg
 Dimensions: 24x14x41 cm
 Stem stroke: 15 cm
 Bead breaking power: **20.000 kg**
 Max. dimensions of tyres: 35" to 63"
 Max. operating pressure: 700 bar

Caractéristiques

Poids: 16 kg
 Dimensions: 24x14x41 cm
 Course de détalonnage: 15 cm
 Puissance détalonnage: **20.000 kg**
 Dimensions pneus max: 35" a 63"
 Pression de fonct. max: 700 bar

Caratteristiche

Peso attrezzo: 16 kg
 Dimensione attrezzo: 24x14x41 cm
 Corsa stelo stallonatore: 15 cm
 Potenza stallonatura: **20.000 kg**
 Dimensioni pneumatici max: 35" a 63"
 Pressione di esercizio max: 700 bar



MADE IN ITALY





Via del Commercio 15 -37066-Sommacampagna-Verona-ITALY
 TEL: +39 045 8960428 FAX: +39 045 8978641
 E-MAIL: info@pmm-montresor.com
 WEB SITE: www.pmm-montresor.com

MANUFACTURER SINCE 1980

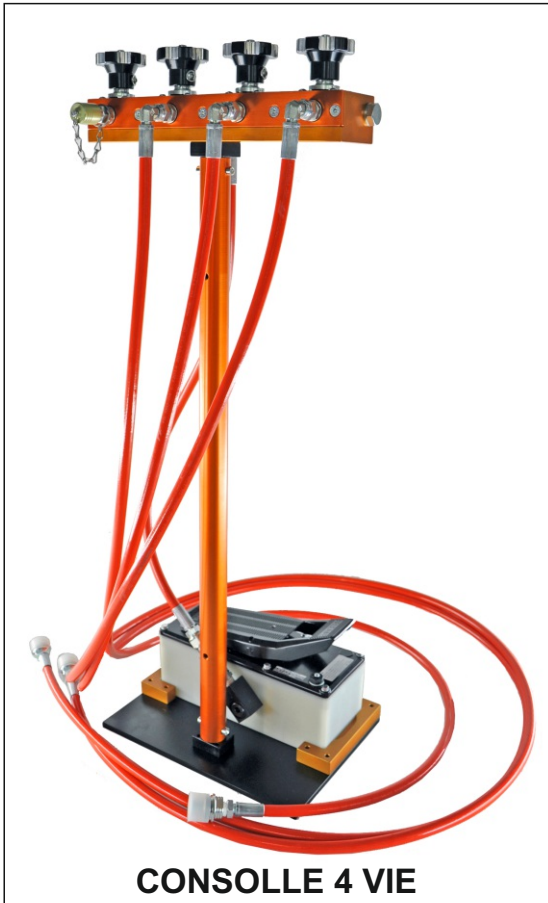

CONSOLLE 4 VIE

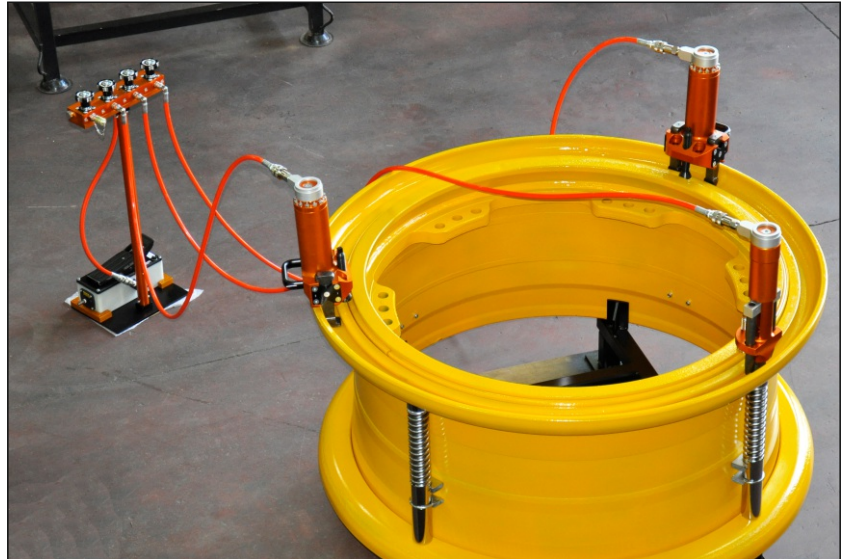

The 4-WAY CONSOLLE is purposely created to manage four tools with a single pump

Le CONSOLLE 4 VOIES est utilisé pour gérer quatre outils avec une seule pompe.

La CONSOLLE 4 VIE serve per gestire quattro attrezzi con una sola pompa.

Characteristics

Weight: 24 kg
 Dimensions: 43x32x90 cm
 Max. operating pressure: 700 bar
 Reservoir capacity: 5 l
 Hoses' length: 2x3,5 mt
 1x2 mt

Caractéristiques

Poids: 24 kg
 Dimensions: 43x32x90 cm
 Pression de fonct. max: 700 bar
 Quantité d'huile: 5 l
 Longueur des flexibles: 2x3,5 mt
 1x2 mt

Caratteristiche

Peso attrezzo: 24 kg
 Dimensione attrezzo: 43x32x90 cm
 Pressione di esercizio max: 700 bar
 Contenuto olio: 5 l
 Lunghezza tubi: 2x3,5 mt
 1x2 mt





Via del Commercio 15 -37066-Sommacampagna-Verona-ITALY
 TEL: +39 045 8960428 FAX: +39 045 8978641
 E-MAIL: info@pmm-montresor.com
 WEB SITE: www.pmm-montresor.com

MANUFACTURER SINCE 1980

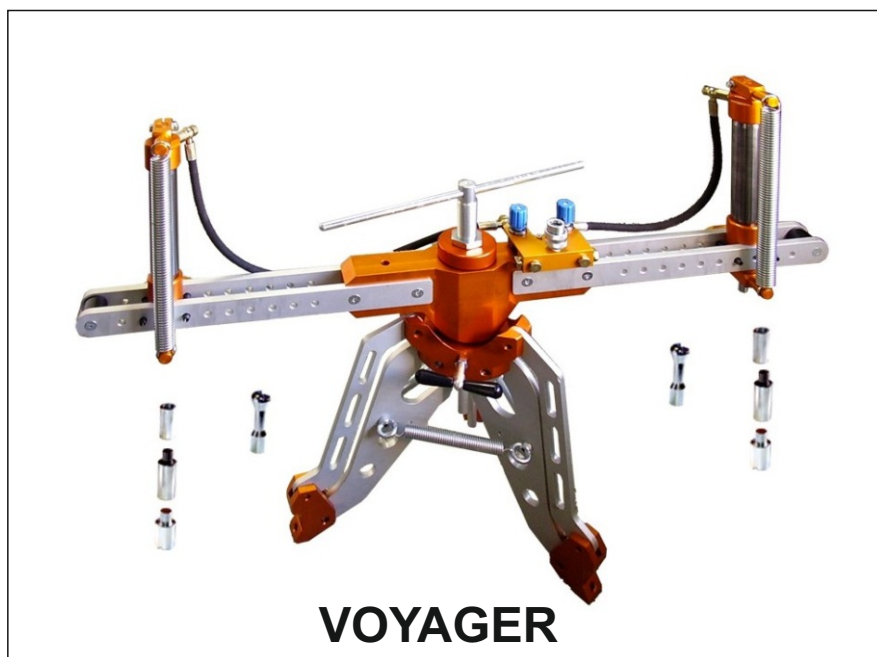

VOYAGER



VOYAGER is a conic rings alignment machine for E.M. on 3 and 5 pieces from 25" to 35". Easy assembly of O-Ring and ring stop-seeger. All operations can be performed by an operator only. The peculiarity of this unit is to rotate of 360°, this allows to work on any point of the rim.

VOYAGER est un outil à l'alignement des anneaux coniques pour les engins de terrassement de 3 à 5 pièces de 25" à 35". Montage facile du joint et de la bague de butée. Toute opération peut être faite par un seul opérateur. La particularité de cet outil est sa rotation de 360° qui permet de travailler sur n'importe quel point de la jante.

Il VOYAGER è una macchina per il montaggio degli anelli conici su cerchioni sia a 3 pezzi che a 5 pezzi da 25" a 35". Facilita il montaggio della guarnizione O-Ring e dell'anello di arresto-seeger. Tutte le operazioni sono eseguibili da un operatore solo. La peculiarità di questa macchina sta nella possibilità di ruotare di 360°, ciò permette di lavorare su qualsiasi punto del cerchio.

Characteristics

Weight: 24 kg+15 kg= 39 kg
 Dimensions: 130x60x14 cm
 Stem stroke: 24 cm
 Bead breaking power: 5000 kg
 Clamping power: manual
 Max. dimensions of tyres: from 25" to 35"
 Max. operation pressure: 700 bar

Caractéristiques

Poids: 24 kg+15 kg= 39 kg
 Dimensions: 130x60x14
 Course de détalonnage: 24 cm
 Puissance détalonnage: 5000 kg
 Puissance blocage: manuel
 Dimensions pneus max: da 25" a 35"
 Pression de fonct. max: 700 bar

Caratteristiche

Peso: 24 kg+15kg= 39 kg
 Dimensioni: 130x60x14 cm
 Corsa stelo stallonatore: 24 cm
 Potenza stallonatura: 5000 kg
 Potenza bloccaggio: manuale
 Dimensioni pneumatici max: da 25" a 35"
 Pressione di esercizio max: 700 bar



MADE IN ITALY



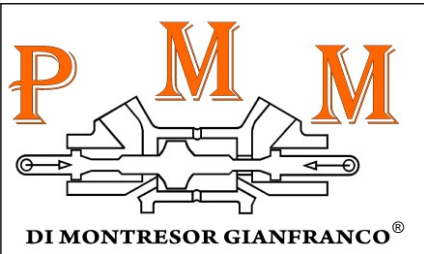

Via del Commercio 15 -37066-Sommacampagna-Verona-ITALY
 TEL: +39 045 8960428 FAX: +39 045 8978641
 E-MAIL: info@pmm-montresor.com
 WEB SITE: www.pmm-montresor.com

MANUFACTURER SINCE 1980



Characteristics

Weight: 1.100 kg
 Dimensions: 334x198x182 cm
 Voltage power supply: 400V - 50HZ
 Electric power: 2,2KW
 Max. operation pressure: 250 bar
 Reservoir capacity: 15 l

Caractéristiques

Poids: 1.100 kg
 Dimensions: 334x198x182 cm
 Alimentation de tension: 400V - 50HZ
 Electricité: 2,2KW
 Pression de fonct. max: 250 bar
 Quantité d'huile: 15 l

Caratteristiche

Peso: 1.100 kg
 Dimensioni: 334x198x182 cm
 Tensione- Alimentazione: 400V - 50HZ
 Potenza elettrica: 2,2 KW
 Pressione di esercizio max: 250 bar
 Contenuto olio: 15 l

MADE IN ITALY
 ••CE••





Via del Commercio 15 -37066-Sommacampagna-Verona-ITALY
TEL: +39 045 8960428 FAX: +39 045 8978641
E-MAIL: info@pmm-montresor.com
WEB SITE: www.pmm-montresor.com

MANUFACTURER SINCE 1980



POMPA M 400

Characteristics

Weight: 4,9 kg
Dimensions: 43x14,5x10,5 cm
Max. operation pressure: 400 bar
Reservoir capacity: 0,4 l

Caractéristiques

Poids: 4,9 kg
Dimensions: 43x14,5x10,5 cm
Pression de fonct. max: 400 bar
Quantité d'huile: 0,4 l

Caratteristiche

Peso: 4,9 kg
Dimensioni: 43x14,5x10,5 cm
Pressione di esercizio max: 400 bar
Contenuto olio: 0,4 l



MADE IN ITALY





DI MONTRESOR GIANFRANCO®

Via del Commercio 15 -37066-Sommacampagna-Verona-ITALY
TEL: +39 045 8960428 FAX: +39 045 8978641
E-MAIL: info@pmm-montresor.com
WEB SITE: www.pmm-montresor.com

MANUFACTURER SINCE 1980



POMPA M 700

Characteristics

Weight: 5,7 kg
Dimensions: 62x14x16 cm
Max. operation pressure: 700 bar
Reservoir capacity: 0,750 l

Caractéristiques

Poids: 5,7 kg
Dimensions: 62x14x16 cm
Pression de fonct. max: 700 bar
Quantité d'huile: 0,750 l

Caratteristiche

Peso: 5,7 kg
Dimensioni: 62x14x16 cm
Pressione di esercizio max: 700 bar
Contenuto olio: 0,750 l



MADE IN ITALY





Via del Commercio 15 -37066-Sommacampagna-Verona-ITALY
TEL: +39 045 8960428 FAX: +39 045 8978641
E-MAIL: info@pmm-montresor.com
WEB SITE: www.pmm-montresor.com

MANUFACTURER SINCE 1980



Hydraulic pump 700 bar, air pressure of 8 bar work

Pompe hydraulique 700 bar, la pression d'air de travail de 8 bar

Pompa idraulica 700 bar, pressione aria di lavoro 8 bar